

(813) 659-1718

3206 Sydney Rd - Plant City FL

CHOO CHOO LAWN EQUIPMENT

Rentals - Parts - Service - Sales

Cub Cadet

GRAVELY

Husqvarna

HONDA
Power
Equipment



STIHL
KOHLER
ENGINES



www.CHOOCHOOPARTS.com



Walk-Behind Lawn Mowers

Parts Manual

Models

911160 - LM21

911182 - LM21

911183 - LM21S

911184 - LM21SW



THE MANUAL

Before you operate your unit, carefully and completely read manuals supplied with the unit. The contents will provide you with an understanding of safety instructions and controls during normal operation and maintenance.

For your safety and the safety of others always read, understand, and follow all DANGER, WARNING, and CAUTION messages found in manuals and on safety decals.

Hardware descriptions are given in decimals.

Decimals to Fractions			
.063	1/16	.563	9/16
.125	1/8	.625	5/8
.188	3/16	.688	11/16
.250	1/4	.750	3/4
.313	5/16	.813	13/16
.375	3/8	.875	7/8
.438	7/16	.938	15/16
.500	1/2	1.00	1

SERVICE AND REPLACEMENT PARTS

When ordering replacement parts or making service inquiries, know the Model and Serial numbers of your unit and engine.

Numbers are located on the product registration card in the unit literature package. They are printed on a serial number label, located on the frame of your unit.

- Record Unit Model and Serial numbers here:

- Record Engine Model and Serial numbers here:

UNAUTHORIZED REPLACEMENT PARTS

Use only Ariens replacement parts. The replacement of any part on this vehicle with anything other than an Ariens authorized replacement part may adversely affect the performance, durability, or safety of this unit and may void the warranty. Ariens disclaims liability for any claims or damages, whether warranty, property damage, personal injury or death arising out of the use of unauthorized replacement parts.

PRODUCT REGISTRATION

The Ariens dealer must register the product at the time of purchase. Registering the product will help the company process warranty claims or contact you with the latest service information. All claims meeting requirements during the limited warranty period will be honored, whether or not the product registration card is returned. Keep a proof of purchase if you do not register your unit.

Customer Note: If the dealer does not register your product, please fill out, sign, and return the product registration card to Ariens or go to www.ariens.com on the internet.

YOUR SATISFACTION IS IMPORTANT

Questions? Please follow these helpful steps:

1. Refer to the manuals supplied with your unit.
They will guide you through safe and proper operation and maintenance.
They contain specifications on your unit.
If your questions are not answered in these manuals, go to step number two.
2. Contact Your Dealer.
Our dealers will be happy to supply any service or advice required to keep your unit operating at peak efficiency.
A factory trained staff is available to support your equipment needs. They stock genuine Ariens parts and lubricants manufactured with the same precision and skill as the original.
If your questions are not resolved by the support staff, ask for the manager or owner.
When contacting your Dealer supply your model and serial numbers.

TO SPEED PARTS ORDERING:

1. Know the model and serial numbers of your unit.
2. Know the part number required.
3. Know the quantity required.
4. Know the part description.

MODELS

Model 911160 (LM21)

4 Cycle-Kohler XT-7
Recoil, Push
Serial No. 000101 and up

Model 911182 (LM21)

4 Cycle-Kawasaki 6.0hp
Recoil, Push
Serial No. 000101 and up

Model 911183 (LM21S)

4 Cycle-Kawasaki 6.0hp
Recoil, Self-Propelled
Serial No. 000101 and up

Model 911184 (LM21SW)

4 Cycle-Kawasaki 6.0hp
Recoil, Self-Propelled, Swivel
Serial No. 000101 and up

TABLE OF CONTENTS

DECALS

Decals 4

MAIN FRAME

Handlebar and Controls 6

Mower Pan and Bag 8

WHEELS

Wheels and Adjusters 10

Friction Wheel and Adjusters 12

Swivel Wheels and Brackets 14

ENGINE

Engine, Blade, Belt 15

DECALS

Model 911160, 182, 183, 184

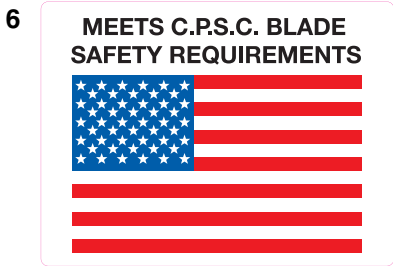
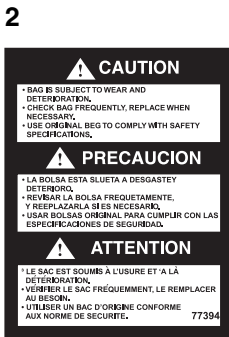
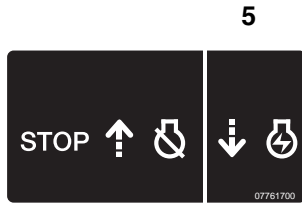
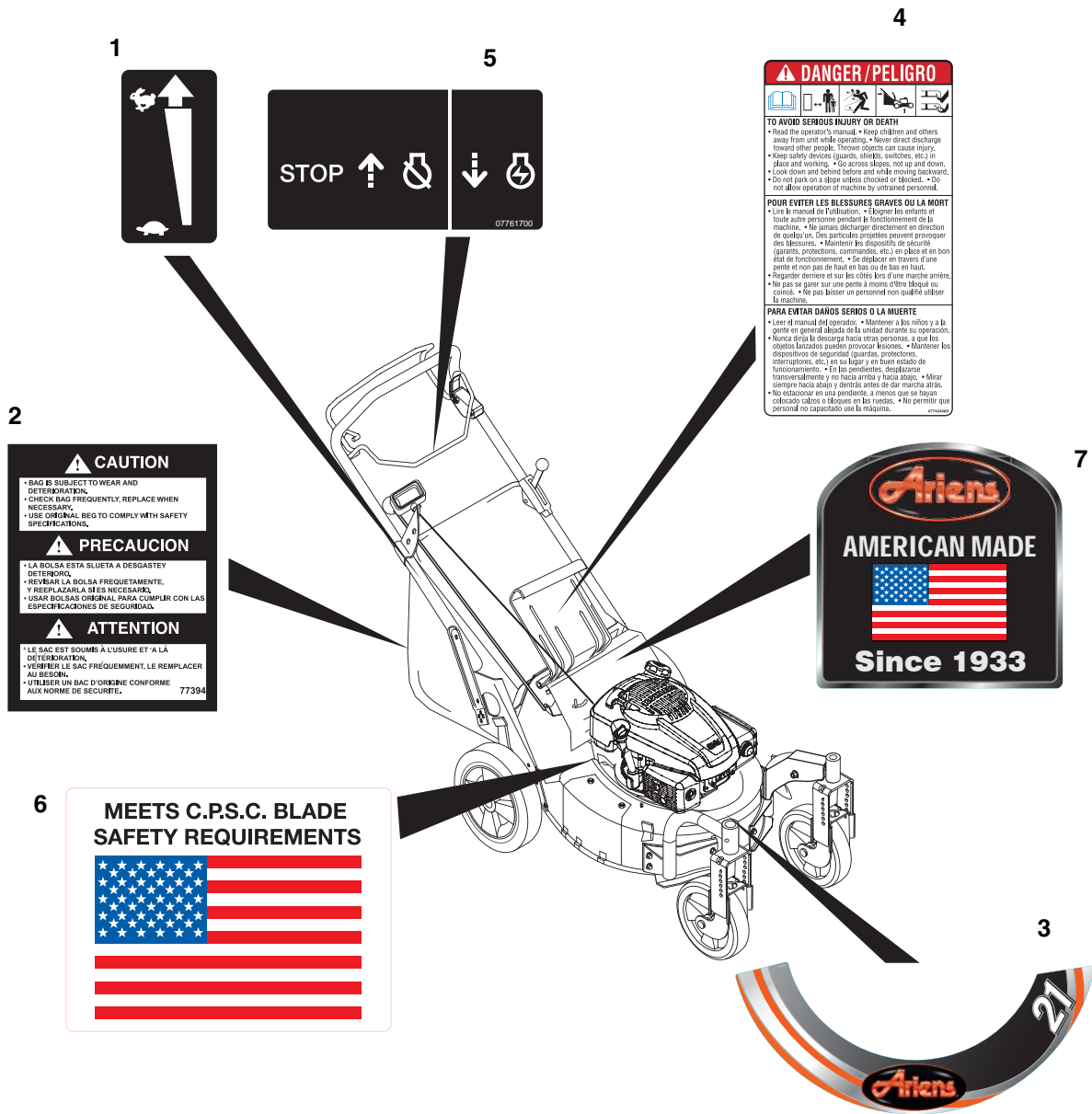

DECALS

Model 911160, 182, 183, 184

Item	Part No.	Qty.	Description
1	07760700	1	Decal, Speed Control
2	07739400	1	Label, Bagger 21"
3	01284700	1	Decal, Ariens Deck
4	07742400	1	Decal, Bilingual Danger
5	07761700	1	Decal, Engine Control
6	07700001	1	Decal, CPSC/USA Flag
7	07800224	1	Decal, American Made Ariens

HANDLEBAR AND CONTROLS

Model 911160, 182, 183, 184

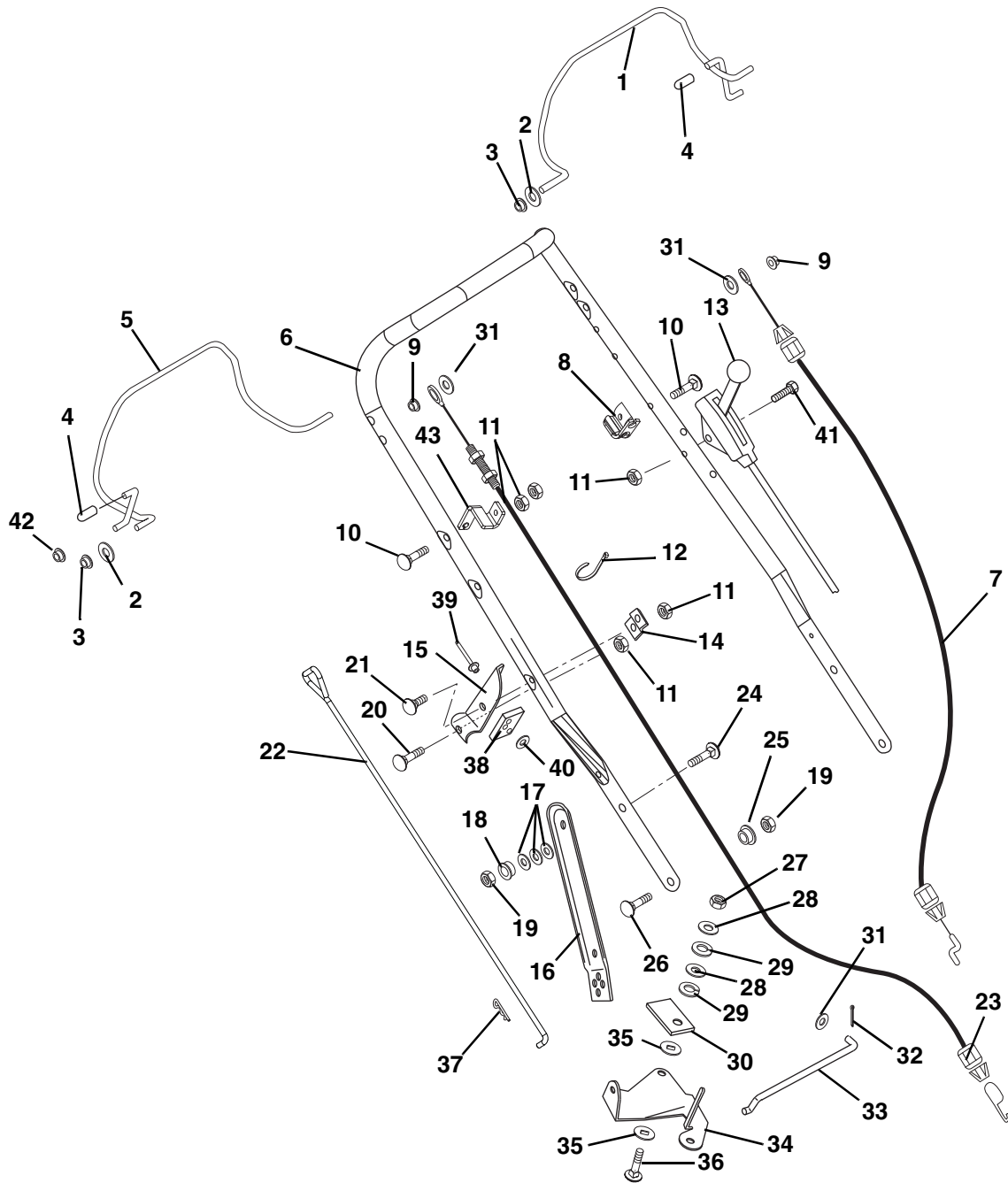

Item	Part No.	Qty.	Description
1	01245151	1	Bail, Engine
2	06437200	4	Washer, Flat Steel .32 x .44 x .44 x .56 (911183, 184)
	06437200	2	Washer, Flat Steel .32 x .44 x .44 x .56 (911160, 182)
3	05514500	4	Bushing, Flange .325 x .688 x .560 (911183, 184)
	05514500	2	Bushing, Flange .325 x .688 x .560 (911160, 182)
4	07517000	2	Cap, Vinyl .25 I.D. (911183, 184)
	07517000	1	Cap, Vinyl .25 I.D. (911160, 182)
5	01245251	1	Traction Bail (911183, 184)
6	01330051	1	Handlebar

HANDLEBAR AND CONTROLS

Model 911160, 182, 183, 184

Item	Part No.	Qty.	Description
7	01282000	1	Cable, OPC (911160)
	06900014	1	Cable, Engine Kawasaki (911182, 183)
	01292500	1	Cable, Engine Kawasaki (911184)
8	01245600	2	Cable, Anchor
9	02215300	2	Push Nut, .25
10	06220100	2	Bolt, Round Head Square Neck .25-20 x 1.25 (911183, 184)
	06220100	1	Bolt, Round Head Square Neck .25-20 x 1.25 (911160, 182)
11	06529700	5	Nut, Locking Center .25-20 (911183, 184)
	06529700	3	Nut, Locking Center .25-20 (911182, 160)
12	07517300	3	Cable Tie
13	06948100	1	Cable, Lockout Control (911184)
14	01141851	1	Brace, Speed Control (911183, 184)
15	01137451	1	Bracket, Speed Control (911183, 184)
16	01150051	1	Link, Handlebar Adjuster Left Hand
	01150151	1	Link, Handlebar Adjuster Right Hand
17	01178700	6	Washer, Bellville Spring
18	05514900	2	Bushing, Flange .325 x .50 x .513 x .875
19	06529800	4	Nut, Locking Center .31-18
20	06222300	1	Bolt, Round Head Square Neck .25-20 x 1.38
21	06220600	1	Bolt, Round Head Square Neck .25-20 x .50 Grade
22	03256800	1	Rod, Speed Control (911183, 184)
23	06900013	1	Traction Cable (911183, 184)
24	06216100	2	Bolt, Round Head Square Neck .31-18 x 1.00 Grade 5
25	01305900	2	Shoulder Spacer
26	06215700	2	Bolt, Round Head Square Neck .31-18 x .75 Grade 5
27	06529600	1	Nut, Locking Center .38-16 (911183, 184)
28	06436200	2	Washer, Flat Steel .406 x .812 x .065 (911183, 184)
29	06306500	2	Washer, Lock .375 x .115 Heavy (911183, 184)
30	01154800	1	Pressure Flange (911183, 184)
31	06437300	3	Washer, Flat Steel .281 x .62 x .065 (911183, 184)
32	06712400	1	Pin, Cotter .06 x .50 (911183, 184)
33	01126100	1	Shift Link (911183, 184)
34	01123900	1	Bell Crank, Speed Control (911183, 184)
35	01123800	2	Friction Washer (911183, 184)
36	06222200	1	Bolt, Round Head Square Neck .38-16 x 1.25 (911183, 184)
37	06713500	1	Pin, Hair Internal .08 x .18 x 1.18 (911183, 184)
38	01173800	1	Support Pad
39	06815700	2	Rivet .187 x .575
40	06442700	2	Washer, Flat Steel .219 x .50 x .049
41	06209300	1	Bolt, Round Head Square Neck .25-20 x 2.00 Grade 5 (911184)
42	07008200	4	Nut, Push .312
43	01245451	1	Anchor, Cable (911183, 184)

MOWER PAN AND BAG

Model 911160, 182, 183, 184

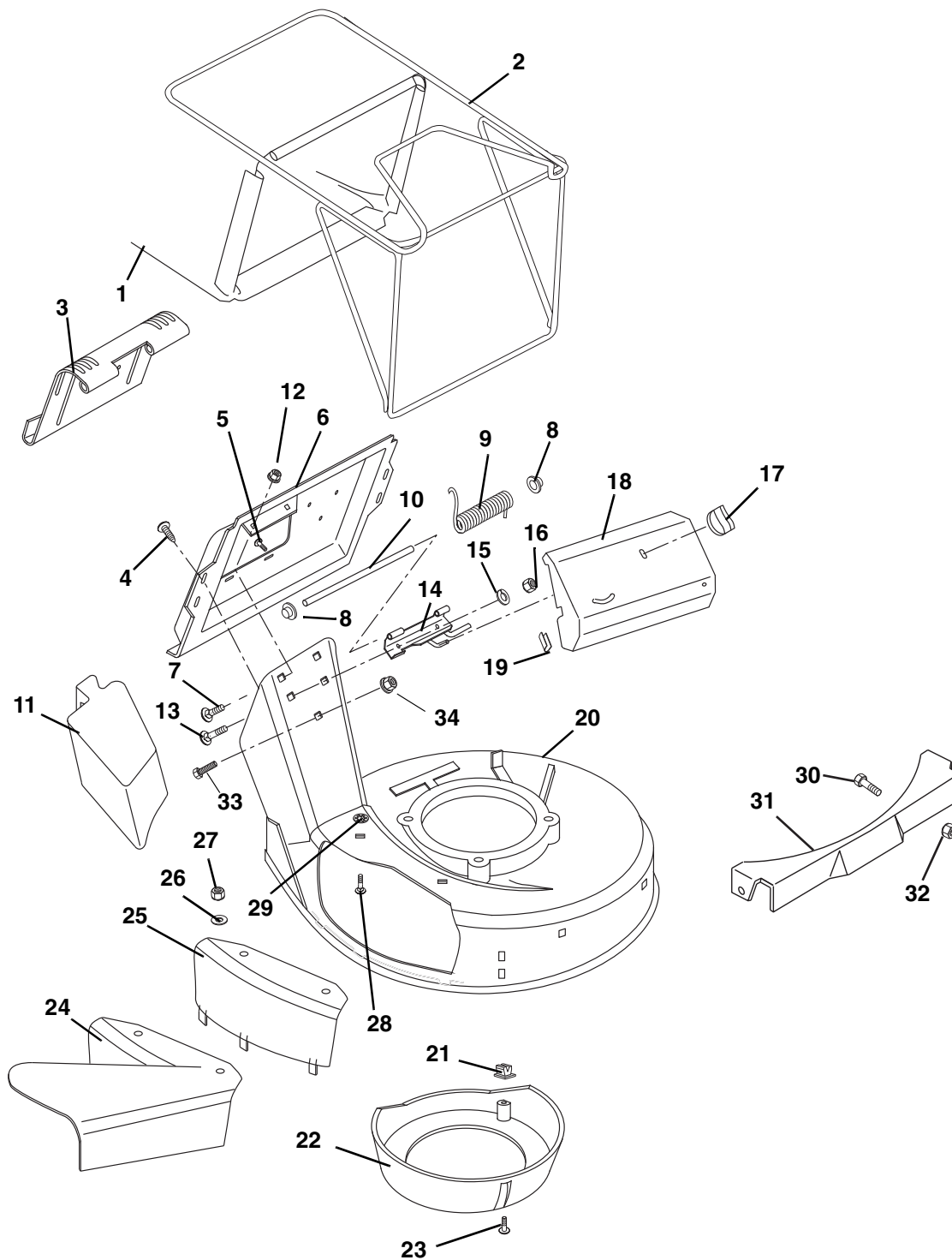

MOWER PAN AND BAG

Model 911160, 182, 183, 184

Item	Part No.	Qty.	Description
1	01180500	1	Bag, Consumer Black
2	01241851	1	Frame, Bagger
3	01136559	1	Door, Catcher Plate
4	07411900	4	Screw, Tapping Hex Washer 12-24 x .50
5	07414900	2	Screw, Tapping 10-24 x .38 Pan Head
6	01159759	1	Plate, Catcher
7	06220600	2	Bolt, Round Head Square Neck .25-20 x .50 Grade 5
8	02215300	2	Nut, Push
9	08322400	1	Spring, Torsion .120 x .68 x 3.09
10	01141000	1	Pin, Door
11	01163500	1	Mulch Master Plug
12	06530100	2	Nut, Locking Flange .25-20
13	06219900	2	Bolt, Round Head Square Neck .25-20 x .75 Grade 5
14	01155559	1	Hinge Base Weldment (911183, 184)
	01138259	1	Hinge Base (911160, 182)
15	06308000	2	Washer, Locking .25 x .077
16	06533200	2	Nut, Hex .25-20
17	01159300	1	Nut, Wing (911183, 184)
18	04042459	1	Drive Cover (911183, 184)
19	01155400	2	Trim Bumper
20	51107500	1	Mower Pan Head with Decals (911183, 184)
	51107600	1	Mower Pan Head with Decals (911160, 182)
21	07507600	3	Grommet, Plastic
22	01173700	1	Baffle, Center
23	07415000	3	Screw, Tapping 10-16 x .62 Hex Washer Head
24	01180200	1	Side Discharge Assembly
25	01180351	1	Side Discharge Cover
26	06436200	2	Washer, Flat Steel .406 x .812 x .065
27	06530200	2	Nut, Locking Nylon .312-18
28	06214100	2	Bolt, Round Head Square Neck .31-18 x .75 Grade 2
29	06514900	2	Nut, Push .312
30	06222000	2	Bolt, Round Head Square Neck .31-18 x .50 Grade 5 (911160, 182, 183)
31	01183559	1	Front Panel (911160, 182, 183)
32	06543100	2	Nut, Locking-Top-Flange .31-18 (911160, 182, 183)
33	05967000	1	Bolt, Hex .38-16 x .50 Grade 5 (911160, 182)
34	06534900	1	Nut, Locking Flange Nut, .375-16 (911160, 182)

WHEELS AND ADJUSTERS

Model 911160, 182, 183, 184

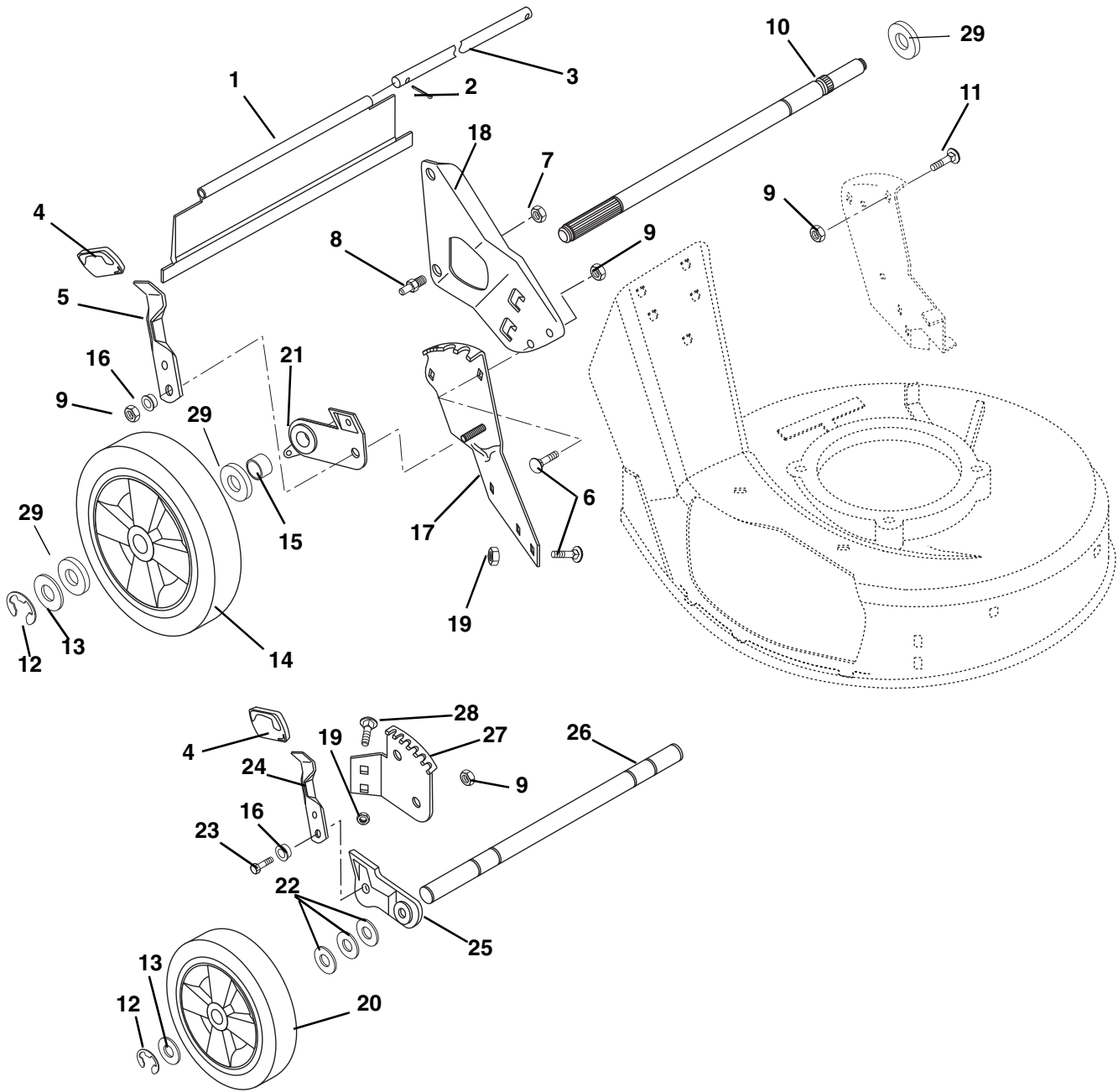

Item	Part No.	Qty.	Description
1	07522300	1	Rear Protective Guard, Self Propelled (911183, 184)
	07522400	1	Rear Protective Guard, Push (911160, 182)
2	06712400	3	Pin, Cotter .06 x .50
3	01140000	1	Rod
4	07513600	4	Knob
5	01242000	2	Lever, Height Adjustment
6	06212200	10	Bolt, Round Head Square Neck .31-18 x .62
7	06529600	2	Nut, Locking Center .38-16

WHEELS AND ADJUSTERS

Model 911160, 182, 183, 184

Item	Part No.	Qty.	Description
8	01167100	2	Handlebar Stud
9	06543100	9	Nut, Locking-Top-Flange Center .31-18
10	01149500	1	Rear Axle (911183, 184)
	01171900	1	Rear Axle (911160, 182)
11	06221800	1	Bolt, Round Head Square Short Neck .31-18 x 1.00
12	05710200	2	Ring, Retaining External .50 x .042 (911184)
	05710200	4	Ring, Retaining External .50 x .042 (911160, 182, 183)
13	06436600	10	Washer, Flat Steel .505 x .88 x .072 (911160, 182)
	06436600	2	Washer, Flat Steel .505 x .88 x .072 (911184)
14	07151200	1	Wheel, Left Hand Rear (911183, 184)
	07151200	2	Wheel, Right Hand Rear (911160, 182)
	07151500	1	Wheel, 10.50" (911183, 184)
	07103900	2	Tire Skin 10 x 2.00 (911160, 183, 184)
15	01149600	2	Spacer Tube (911183, 184)
	01149800	1	Spacer Tube (Left hand side only.) (911160, 182)
16	05514800	4	Bushing, Flange .312 x .50 x .344 x .88 (911160, 182, 183)
	05514800	2	Bushing, Flange .312 x .50 x .344 x .88 (911184)
17	01154251	1	Rear Quadrant-Left Hand
	01154351	1	Rear Quadrant-Right Hand
18	01137251	1	Bracket, Handlebar Mounting-Right Hand
	01137151	1	Bracket, Handlebar Mounting-Left Hand
19	06543100	6	Nut, Locking Top Flange .31-18 (911184)
	06543100	10	Nut, Locking Top Flange .31-18 (911160, 182, 183)
20	07149900	2	Wheel, Front
21	04089400	1	Rear Adjuster Bracket-Left Hand (911183, 184)
	01150400	1	Rear Bracket and Bearing Assembly (911183, 184)
	01131200	1	Rear Bracket and Bearing Assembly Left Hand (911160, 182)
	01131300	1	Rear Bracket and Bearing Assembly Right Hand (911160, 182)
22	06441100	6	Washer, Flat Steel .520 x .827 x .062 (911160, 182, 183)
23	05946900	2	Bolt, Hex .31-18 x 1.00 Grade 5 (911160, 182, 183)
24	01120000	2	Lever, Front Height Adjustment (911160, 182, 183)
25	01119800	1	Left Hand Bracket Assembly (911160, 182, 183)
	01119900	1	Right Hand Bracket Assembly (911160, 182, 183)
26	01168900	1	Front Axle (911160, 182, 183)
27	01154051	1	Front Quadrant, Left Hand (911160, 182, 183)
	01154151	1	Front Quadrant, Right Hand (911160, 182, 183)
28	06222000	4	Bolt, Round Head Square Neck .31-18 x .50 Grade 5 (911160, 182, 183)
29	05532400	3	Spacer .531 x 1.00 x .195 (911160, 182)

FRICION WHEEL AND DRIVE

Model 911183, 184

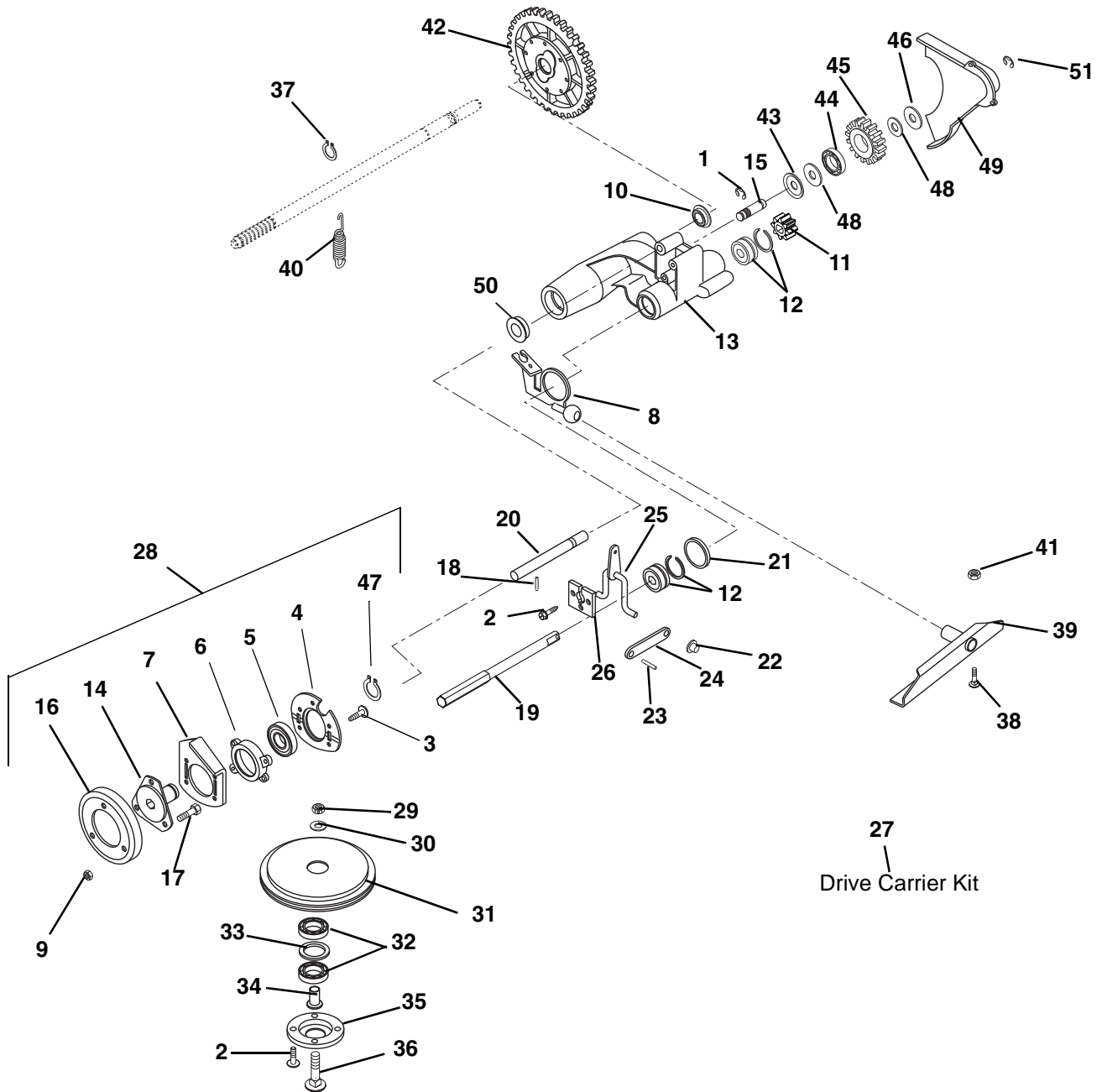

FRICION WHEEL AND DRIVE

Model 911183, 184

Item	Part No.	Qty.	Description
1	05705900	1	Ring, Retaining External .438 x .035
2	07411900	6	Screw, Tapping 12-24 x .50 Hex Washer Head
3	07415100	4	Screw, Tapping 5 x 0.8 x 16MM
4	01119200	1	Bearing Retainer
5	05416000	1	Bearing Ball 1.00 x 2.00 x .56
6	01131800	1	Bearing Retainer
7	00174500	1	Bearing Plate
8	01245700	1	Drive Actuator Weldment
9	06529700	3	Nut, Locking Center .25-20
10	05417500	1	Bearing, Ball .625 x 1.38 x .44
11	02201101	1	Pinion, D-Shaft
12*	05480000	2	Bearing, Ball .50 x 1.375 x .437
13	01140600	1	Drive Mount
14	01133500	1	Hub, Friction Wheel
15	01139700	1	Idler Shaft
16	03248300	1	Disc, Friction
17	05947900	3	Bolt, Hex .25-20 x .50 Grade 5
18	05800500	1	Pin, Roll .188 x .88
19	01281700	1	Shaft, Friction Disk
20	01125100	1	Rod, Guide
21	06421600	1	Washer, Flat Steel 1.390 x 2.00 x .020
22	02215300	2	Push Nut .25
23	05803500	2	Pin, Roll .125 x .50
24	01124200	2	Shift Link
25	01123600	1	Shift Arm Weldment
26	01125000	1	Retainer Plate
27	51108900	1	Kit, LM Drive Carrier (Includes Items 1 - 26)
28	51109700	1	Friction Wheel Assembly
29	06529800	1	Nut, Locking Center .31-18
30	06439100	1	Washer, Flat Steel .38 x .87 x .179
31	01127300	1	Friction Sheave
32*	05435100	2	Bearing, Ball .625 x 1.375 x .43
33	06420200	1	Washer, Flat Steel 1.062 x 1.344 x .032
34	01127400	1	Spindle, Bearing
35	01127500	1	Bearing, Retainer
36	06220200	1	Bolt, Round Head Square Neck .31-18 x 1.75 Grade 5
37	05711900	2	Ring, Retaining External .579 x .930
38	06212200	2	Bolt, Round Head Square Short Neck .31-18 x .62
39	01161951	1	Pivot Channel Weldment
40	08325200	1	Spring, Tension .051 x .60 x 2.25
41	06543100	2	Nut, Locking-Top-Flange .31-18
42	51102400	1	Differential Assembly
43	01135100	1	Retainer
44*	05408000	1	Bearing, Ball .50 x 1.38 x .437
45	01131700	1	Idler Gear
46	06425300	1	Washer, Flat Steel .531 x 1.00 x .063
47	05706200	1	Ring, Retaining External 1.00 x .042
48	06441100	2	Washer, Flat Steel .520 x .827 x .062
49	01121051	1	Gear Cover
50*	05417600	1	Bearing, Ball .625 x 1.383 x .50
51	05705900	1	Ring, Retaining External .438 x .035

* Available as individual components or part of 51105600 Service Kit which consists of (2) 05435100, (1) 05408000, (2) 05480000 and (2) 05417600.

SWIVEL WHEELS AND BRACKETS

Model 911184

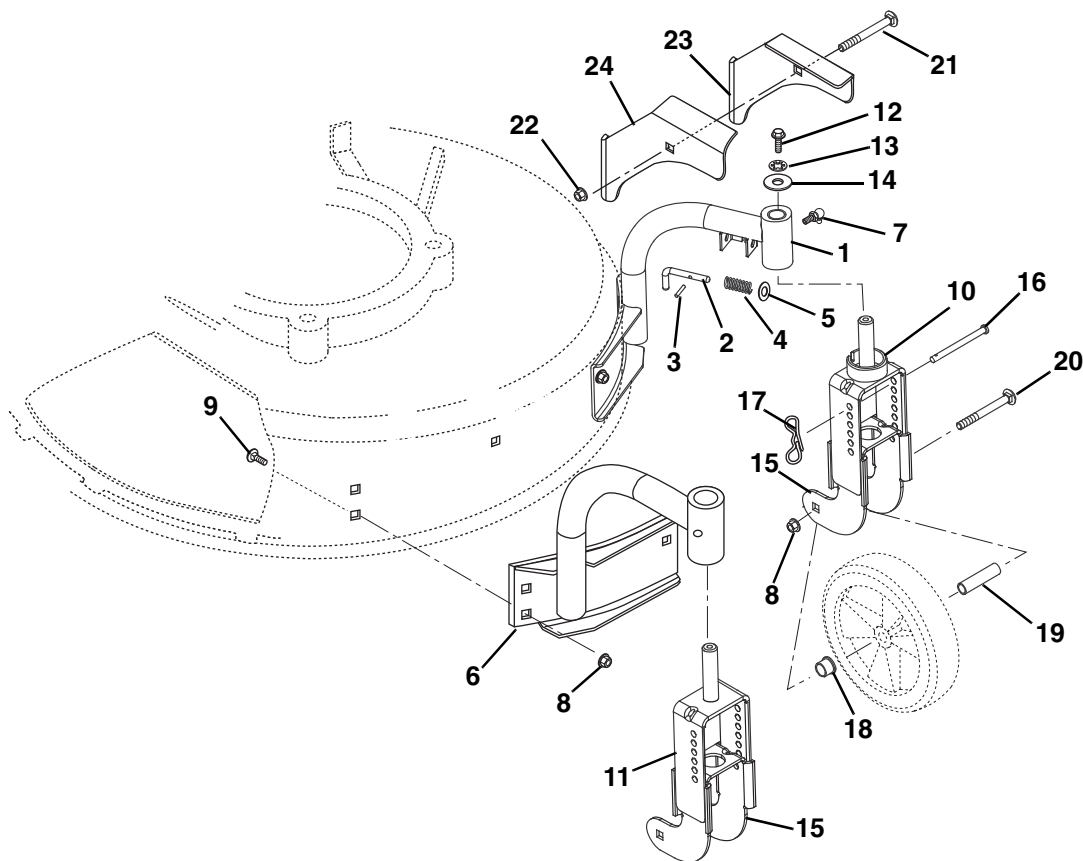

Item	Part No.	Qty.	Description
1	01197059	1	Weldment, Left Hand Mount
2	01196900	1	Pin, Lockout
3	05801000	1	Pin, Roll .094 x .50
4	08337300	1	Spring, Compression - Swivel Lockout
5	06437300	1	Washer, Flat Steel .281 x .62 x .065
6	01197659	1	Weldment, Right Hand Mount
7	07012600	2	Fitting, Lube .25-28 x .256
8	06530400	8	Nut, Spin Lock Flange .312-18
9	06222000	6	Bolt, Round Head Square Neck .31-18 x .50 Grade 5
10	01196759	1	Yoke, Left Hand Outer
11	01197459	1	Yoke, Right Hand Outer
12	05946800	2	Bolt, Hex .25-20 x .75 Grade 5
13	06308000	2	Washer, Locking .25 x .062 Regular
14	06426600	2	Washer, Flat Steel .28 x 1.00 x .063
15	01196600	2	Yoke, Inner
16	06817100	2	Pin, Height Adjustment
17	06700001	2	Pin, Bow Tie Locking Cotter
18	05502100	2	Bushing, Flange .50 x .625 x .50 x .75
19	05533500	2	Spacer, Wheel
20	06212300	2	Bolt, Round Head Square Neck .31-18 x 2.75
21	06222300	1	Bolt, Round Head Square Neck .25-20 x 1.50 Grade 5
22	06530100	1	Nut, Locking Flange .25-20
23	01197359	1	Bracket, Hood Cable Left Hand
24	01198159	1	Bracket, Hood Cable Right Hand

ENGINE, BLADE AND BELT

Model 911160, 182, 183, 184

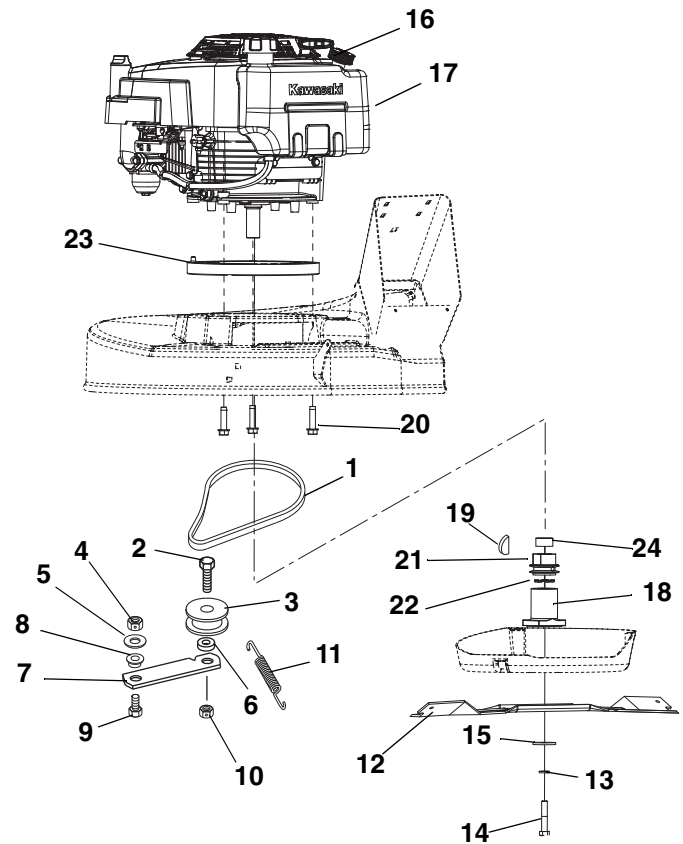
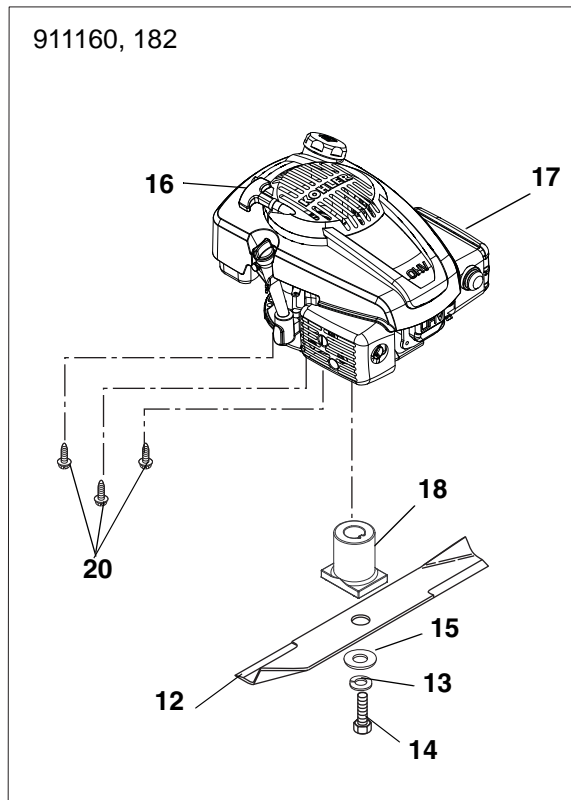

Item	Part No.	Qty.	Description
1	07217100	1	V-Belt 3L Section (911183, 184)
2	05962800	1	Bolt, Hex .44-14 x 1.50 Grade 5 (911183, 184)
3	07313300	1	Idler, Flat 1.75 x .47 (911183, 184)
4	06529800	4	Nut, Locking Center .31 -18 (911183, 184)
5	06437200	1	Washer, Flat Steel .344 x .688 x .065 (911183, 184)
6	05533300	1	Bushing, Sleeve .469 x .75 x .43 (911183, 184)
7	01141200	1	Idler Arm (911183, 184)
8	05515400	1	Bushing, Flange .325 x .501 x .250 x 1.120 (911183, 184)
9	05947000	1	Bolt, Hex .31-18 x .75 Grade 5 (911183, 184)
10	06536400	1	Nut, Locking Center .44-14 (911183, 184)
11	08321100	1	Spring, Tension .043 x .44 x 3.31 (911183, 184)
12	01137000	1	Blade, 21" Mower
13	06308800	1	Washer, Locking .38 x .094
14	05976600	1	Bolt, Hex .38-24 x 2.00 Grade 8 (911160, 182)
	05990000	1	Bolt, Hex .38-24 x 2.75 Grade 8 (911183, 184)
15	06441700	1	Washer, Flat Steel .390 x 1.50 x .125
16	01157100	1	Recoil Start Handle
17	08200312	1	Engine, Kohler XT-7 (911160)
	08200532	1	Engine, Kawasaki FJ180V Commercial (911182, 183, 184)
18	09735100	1	Adapter, Blade (911160, 182)
	09736900	1	Adapter, Blade (911183, 184)
19	06600900	1	Key, Woodruff .156 x .625 x .25 SAE #6 (911183, 184)
20	07414100	3	Screw, Tapping .38-16 x 1.00 Hex Washer Head (911160, 182)
	07417400	3	Screw, Tapping .38-16 x 1.50 Hex Washer Head (911183, 184)
21	09737000	1	Pulley, Crank (911183, 184)
22	01192900	1	Washer, Wave .885 x 1.311 x .125 (911183, 184)
23	04042000	1	Plate, Engine Shim (911183, 184)
24	05501011	1	Spacer, .875 x 1.125 x .525 (911183, 184)



Ariens Company
655 West Ryan Street
P.O. Box 157
Brillion, WI 54110-0157
920-756-2141
Fax 920-756-2407
www.ariens.com