

**(813) 659-1718**

3206 Sydney Rd - Plant City FL

**CHOO CHOO LAWN EQUIPMENT**

*Rentals - Parts - Service - Sales*

*Cub Cadet*

**GRAVELY**

**Husqvarna**

**HONDA**  
Power  
Equipment



**STIHL**  
KOHLER  
ENGINES



**[www.CHOOCHOOPARTS.com](http://www.CHOOCHOOPARTS.com)**



# Rider

## Parts Manual

---

Model  
916002 – 34-In. S.D. Deck



## THE MANUAL

---

Before you operate your unit, carefully and completely read manuals supplied with the unit. The contents will provide you with an understanding of safety instructions and controls during normal operation and maintenance.

For your safety and the safety of others always read, understand, and follow all DANGER, WARNING, and CAUTION messages found in manuals and on safety decals.

Hardware descriptions are given in decimals.

Decimals to Fractions			
.063	1/16	.563	9/16
.125	1/8	.625	5/8
.188	3/16	.688	11/16
.250	1/4	.750	3/4
.313	5/16	.813	13/16
.375	3/8	.875	7/8
.438	7/16	.938	15/16
.500	1/2	1.00	1

## SERVICE AND REPLACEMENT PARTS

---

When ordering replacement parts or making service inquiries, know the Model and Serial numbers of your unit.

Numbers are located on the product registration card in the unit literature package. They are printed on a serial number label, located on the frame of your unit.

- Record Unit Model and Serial numbers here:

### UNAUTHORIZED REPLACEMENT PARTS

Use only Ariens replacement parts. The replacement of any part on this vehicle with anything other than an Ariens authorized replacement part may adversely affect the performance, durability, or safety of this unit and may void the warranty. Ariens disclaims liability for any claims or damages, whether warranty, property damage, personal injury or death arising out of the use of unauthorized replacement parts.

## PRODUCT REGISTRATION

---

The Ariens dealer must register the product at the time of purchase. Registering the product will help the company process warranty claims or contact you with the latest service information. All claims meeting requirements during the limited warranty period will be honored, whether or not the product registration card is returned. Keep a proof of purchase if you do not register your unit.

**Customer Note:** If Dealer does not register your product, please fill out, sign and return the product registration card to Ariens or go to [www.ariens.com](http://www.ariens.com).

## YOUR SATISFACTION IS IMPORTANT

---

**Questions? Please follow these helpful steps:**

1. Refer to the manuals supplied with your unit.  
They will guide you through safe and proper operation and maintenance.  
They contain specifications on your unit.  
If your questions are not answered in these manuals, go to step number two.
2. Contact Your Dealer.  
Our dealers will be happy to supply any service or advice required to keep your unit operating at peak efficiency.  
A factory trained staff is available to support your equipment needs. They stock genuine Ariens parts and lubricants manufactured with the same precision and skill as the original.  
If your questions are not resolved by the support staff, ask for the manager or owner.  
When contacting your Dealer supply your model and serial numbers.

### TO SPEED PARTS ORDERING:

1. Know the model and serial numbers of your unit.
2. Know the part number required.
3. Know the quantity required.
4. Know the part description.

# MODEL

---

**Model 916002 (34-Inch Deck)**

Serial No. 101 and up

# TABLE OF CONTENTS

---

## DECALS

---

Decals – Safety And Operation .....	4
Decals – Style .....	5

## FRAME, TRANSAXLE AND GAUGES

---

Frame, Body And Gauges .....	6
Seat And Support .....	8
Transaxle, Drive Motor And Rear Wheels .....	10

## OPERATOR CONTROLS

---

Controllers And Seat Suspension .....	12
Parking Brake .....	14
Directional Control .....	16
Steering Controls .....	18

## ELECTRICAL SYSTEM

---

Batteries, Charger, Guards And Clamp .....	20
Wiring Diagram And Harness .....	21
Continuity Diagram .....	22

## MOWER DECK

---

Mower Deck Lift .....	23
Mower Deck, Motors And Blades .....	24

# DECALS – SAFETY AND OPERATION

Model 916002

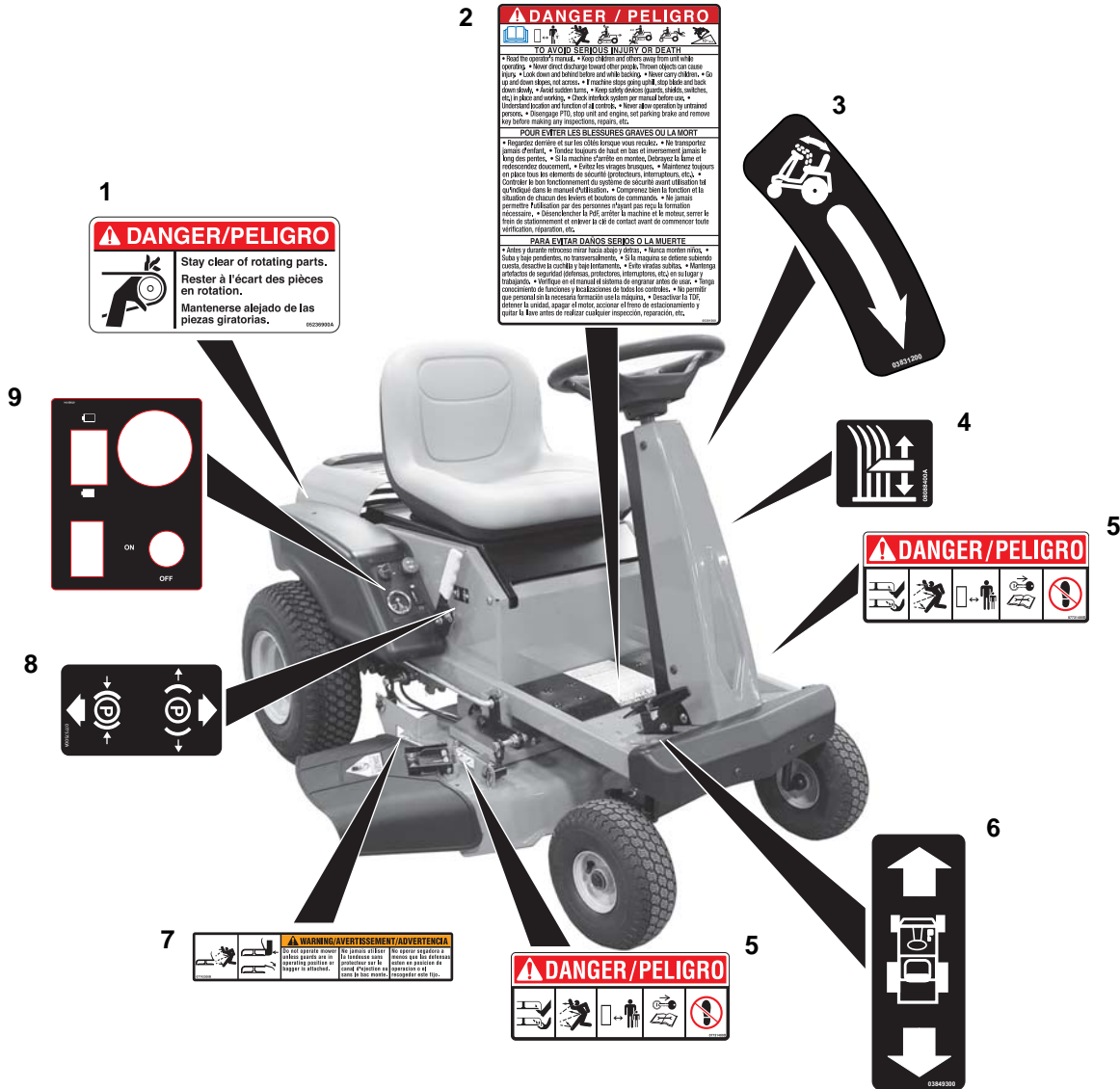

Item	Part No.	Qty.	Description
1	05236900	1	Decal, Danger Belt Rotating
2	05301500	1	Decal, Danger
3	03831200	2	Decal, Seat Release
4	08088400	1	Decal, Cut Height
5	07731400	2	Decal, Mower Pan Danger
6	03849300	1	Decal, Forward/Reverse Pedal
7	07742300	1	Decal, Warning
8	07757500	1	Decal, Parking Brake Lever
9	07800114	1	Decal, Control Panel

# DECALS – STYLE

Model 916002



PA0402

Item	Part No.	Qty.	Description
1	08000229	1	Decal, Ariens Since 1933, Small
2	03827800	1	Decal, Steering Wheel
3	03827700	1	Decal, Front Tower
4	07800034	1	Decal, Deck Size
5	03827600	2	Decal, Kickplate
6	05305100	1	Decal, American Flag

# FRAME, BODY AND GAUGES

Model 916002

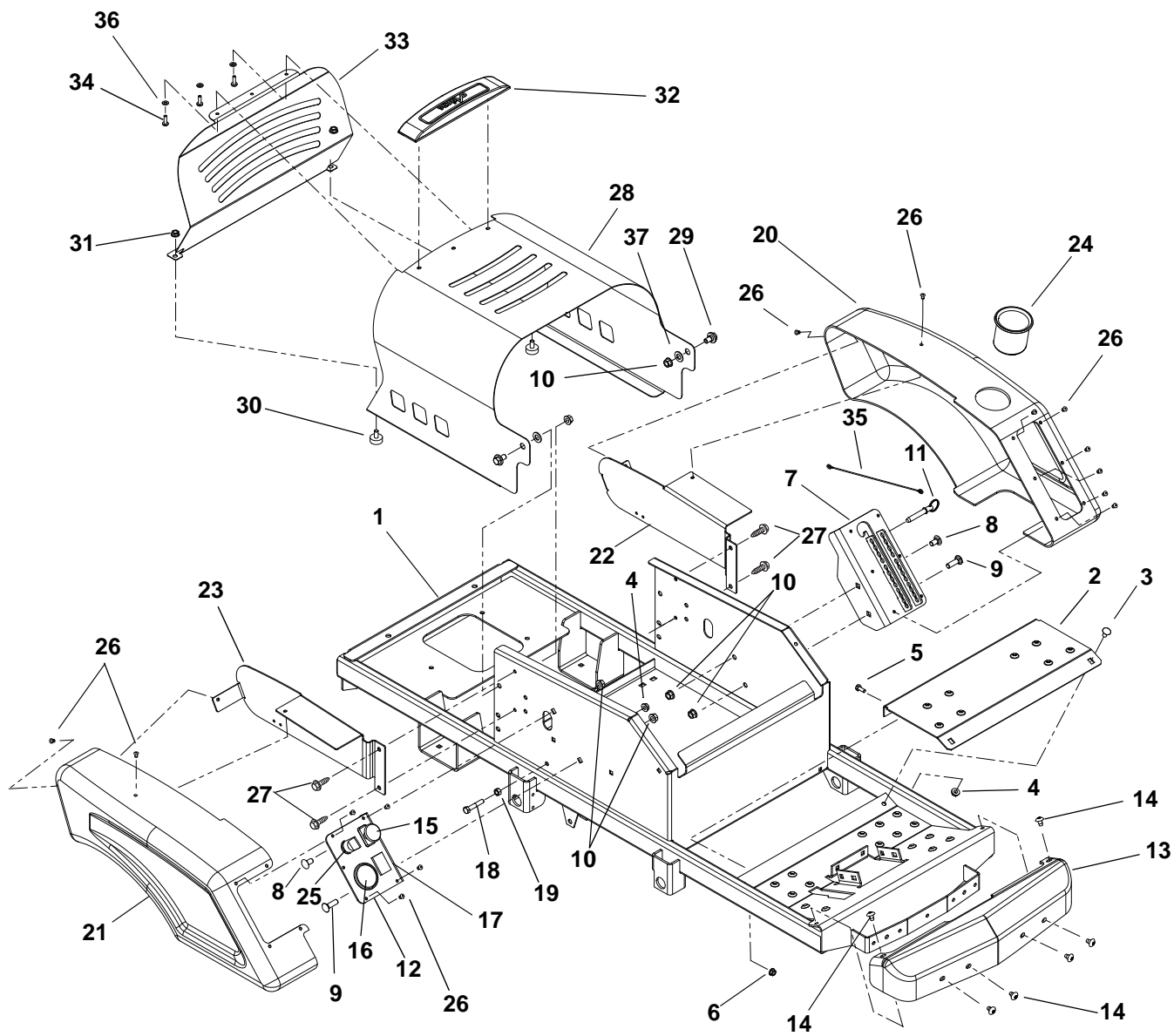

PA0405

# FRAME, BODY AND GAUGES

---

Model 916002

Item	Part No.	Qty.	Description
1	03293359	1	Weldment, Frame
2	03379651	1	Footrest
3	06212200	2	Bolt, Round Head Square Neck .31-18 x .62
4	06543100	3	Nut, Locking Top Flange .31-18
5	05932000	2	Bolt, Hex .25-20 x .50
6	06543500	2	Nut, Locking Top Flange .25-20
7	03390251	1	Weldment, Cut Height Bracket
8	06200004	2	Bolt, Round Head Square Neck .38-16 x .75
9	06224100	2	Bolt, Round Head Square Neck .38-16 x 1.25
10	06542000	6	Nut, Locking Top Flange .38-16
11	01593500	1	Pin, Spring Ball .375 x 1.50
12	03782151	1	Panel, Control
13	03379500	1	Bumper, Front Plastic
14	07400009	6	Screw, Tapping Serrated Head Torx .31-18 x .50
15	01545600	1	Switch, Clutch
16	03796800	1	Meter, Ampere
17	03796700	1	Indicator, Battery Discharge 48V
18	05957400	1	Bolt, Hex .31-18 x 1.75
19	06529200	1	Nut, Hex .31-18
20	03826300	1	Fender, Left Hand
21	03826200	1	Fender, Right Hand
22	03826651	1	Plate, Fender Support Left Hand
23	03826551	1	Plate, Fender Support Right Hand
24	01528500	1	Holder, Cup
25	03796600	1	Switch, 2-Position With Key
26	06830000	14	Rivet, Plastic .195 Diameter
27	07411500	4	Screw, Tapping Hex Head Washer Thread Rolling .31-18 x .50
28	03398359	1	Hood
29	07056700	2	Bolt, Shoulder .375-16 x .135
30	07533600	2	Bumper, Rubber
31	06530400	2	Nut, Spin Lock Flange .312-18
32	03755000	1	Hood Trim, Ariens Small
33	03826751	1	Plate, Hood Backing
34	07400035	3	Screw, Phillips Pan Head 12-11 x .625
35	06900317	1	Lanyard Cable, 12" Nylon
36	06423600	3	Washer, Flat Steel .250 x .500 x .049
37	06443300	2	Washer, Flat Nylon .521 x 1.00 x .08



# SEAT AND SUPPORT

Model 916002

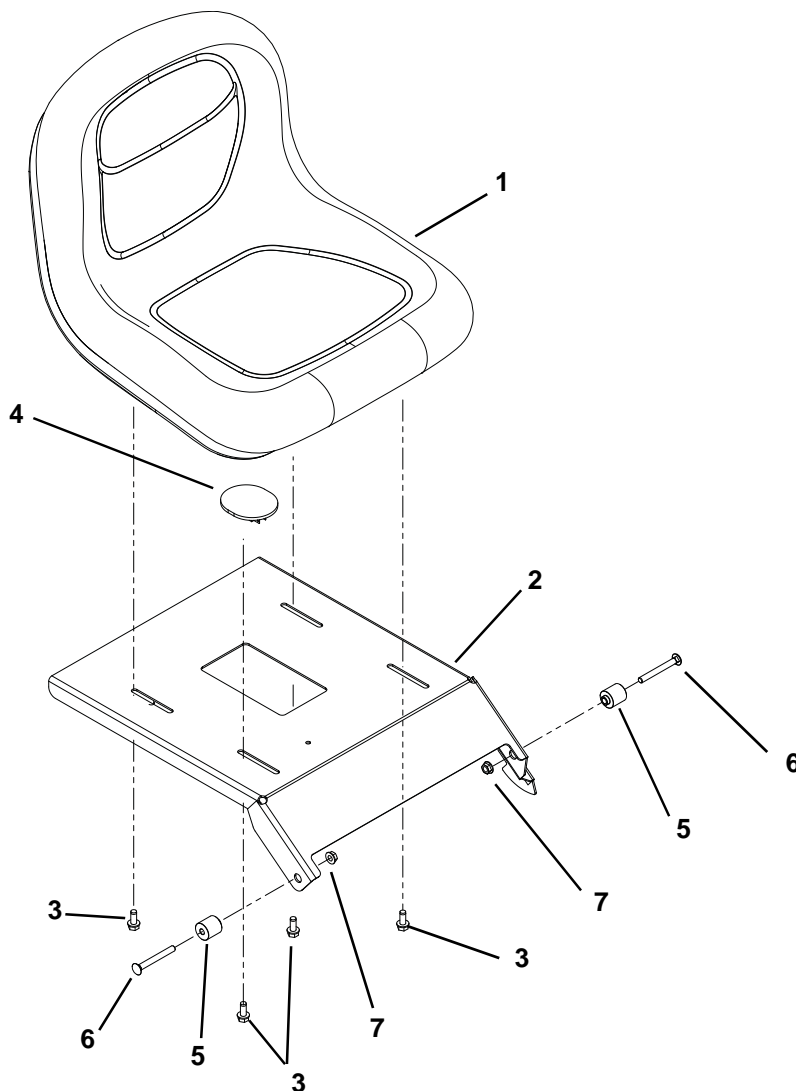

PA0410

Item	Part No.	Qty.	Description
1	03872800	1	Seat, Milsco XB150 Gray
2	03874251	1	Weldment, Seat Plate
3	05900033	4	Bolt, Hex Whiz Head
4	03654200	1	Switch, Seat
5	00476300	2	Spacer
6	06212300	2	Bolt, Round Head Square Neck .31-18 x 2.75
7	06543100	2	Nut, Locking Top Flange .31-18

# NOTES

---

# TRANSAXLE, DRIVE MOTOR AND REAR WHEELS

Model 916002

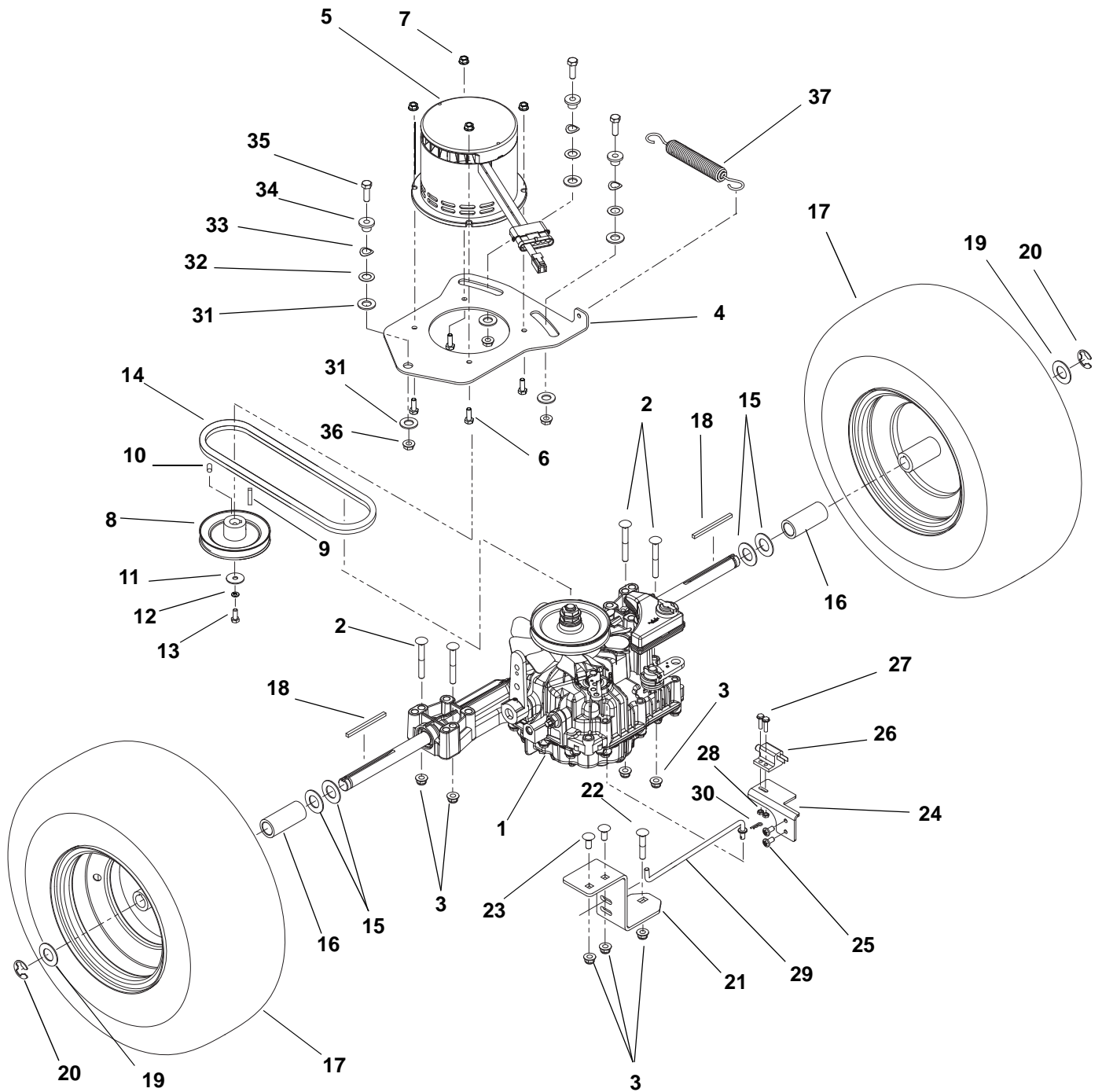

PA0420

# TRANSAXLE, DRIVE MOTOR AND REAR WHEELS

Model 916002

Item	Part No.	Qty.	Description
1	03397300	1	Transmission, Tuff Torque KH64
2	06219400	4	Bolt, Round Head Square Neck .31-18 x 2.50
3	06545400	7	Nut, Nyloc Flange .31-18
4	03367759	1	Plate, Motor Mount
5	03367400	1	Motor, 4 hp Electric Brushless
6	05947700	4	Bolt, Hex .25-20 x 1.00
7	06500012	4	Nut, Nyloc Flange .25-20
8	07318900	1	Sheave, Pump .592 x 4.345
9	06607500	1	Key, Straight 5 mm x 25 mm x 5 mm
10	06000800	2	Screw, Set .25-20 x .38 Socket Head Cup Point
11	06426600	1	Washer, Flat Steel .280 x1.000 x .063
12	06308400	1	Washer, Locking .25 x .062 Regular
13	05975900	1	Bolt, Hex M6-1 x 16
14	07204800	1	V-Belt, SAE 380 28.047 x .406
15	06400333	4	Washer, Thrust .755 x 1.50 x .03
16	05510001	2	Bushing, Sleeve .750 x 1.250 x 2.56
17	07100512	2	Tire/Wheel Assembly 18 x 6.50 2 Ply
18	06600213	2	Key, Square .188 x 3.0 x .188
19	06416100	2	Washer, Hardened Thrust .755 x 1.40 x .062
20	05707400	2	Ring, External Retaining .750 x .050
21	03734851	1	Strap, Torque
22	06220200	1	Bolt, Round Head Square Neck .31-18 x 1.75
23	06215700	2	Bolt, Round Head Square Neck .31-18 x .75
24	03778551	1	Bracket, Mounting
25	07400032	2	Screw, Pan Head .25 x 50
26	03657100	1	Switch, Single Pole Normally Open
27	06116900	2	Screw, Machine 10-24 x .75
28	06536000	2	Nut, Locking Nylon With Insert 10-24
29	03736700	1	Rod, Dump Valve
30	06701900	1	Pin Hair Internal .06 x .18 x .77
31	06443300	6	Washer, Flat Nylon .521 x 1.00 x .08
32	06436000	3	Washer, Flat Steel .505 x .875 x .024
33	06400005	3	Washer, Wave .50 x .75 x .015 .13 FRHT
34	05514900	3	Bushing, Flange .325 x .500 x .513 x .875
35	05901311	3	Bolt, Hex .31-18 x 1.00 Grade 8
36	06543100	3	Nut, Locking Top Flange .31-18
37	08300433	1	Spring, Extension

# CONTROLLERS AND SEAT SUSPENSION

Model 916002

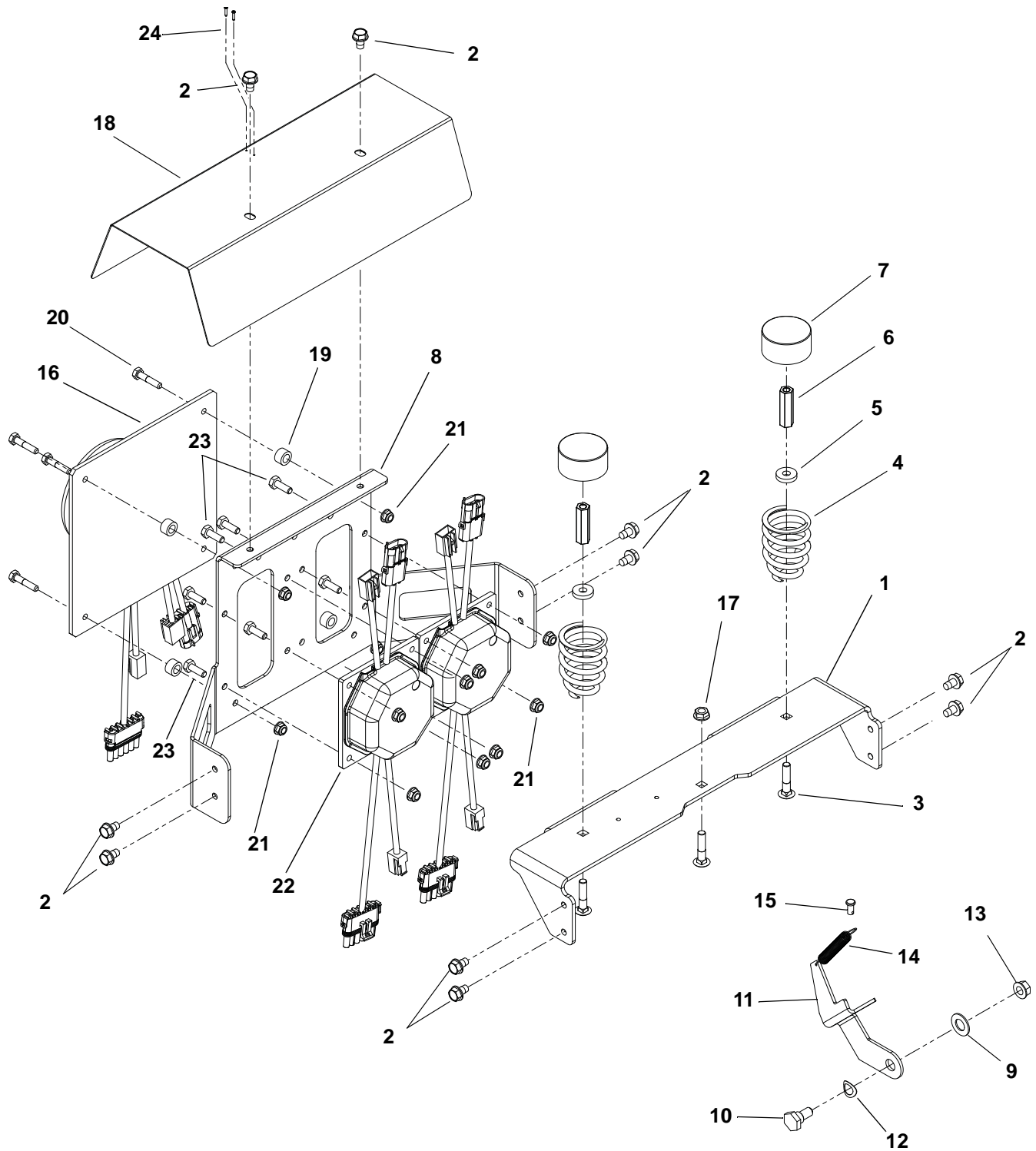

PA0410

# CONTROLLERS AND SEAT SUSPENSION

---

Model 916002

Item	Part No.	Qty.	Description
1	03367351	1	Bracket, Seat Spring
2	07411500	10	Screw, Tapping .31-18 x .50
3	06212100	3	Bolt, Round Head Square Neck .31-18 x 1.50
4	08300021	2	Spring, Seat
5	06439100	2	Washer, Flat Steel .328 x .87 x .179
6	06500015	2	Nut, Coupling .31-18 x 1.75
7	00337700	2	Cap, Plastic 2.00 x 1.00
8	03381251	1	Mount, Controller
9	06425300	1	Washer, Flat Steel .531 x 1.00 x .063
10	07000034	1	Bolt, Shoulder
11	03826451	1	Latch, Seat
12	06400005	1	Washer, Wave .50 x .75 x .015 .13 FRHT
13	06542000	1	Nut, Locking Top Flange .38-16
14	08314900	1	Spring, Extension
15	06809700	1	Pin, Clevis .25 x .406
16	03829500	1	Assembly, Drive Controller
17	06543100	1	Nut, Locking Top Flange .31-18
18	03835151	1	Shield, Water
19	05522100	4	Spacer
20	05947400	4	Bolt, Hex .25-20 x 1.25
21	06500012	12	Bolt, Hex .25-20 Nyloc Flange
22	03829600	2	Controller, Deck
23	05946800	8	Bolt, Hex .25-20 x .75
24	07400102	2	Screw, Tapping 6-32 x .75 Pan Head Flat Tip

# PARKING BRAKE

Model 916002

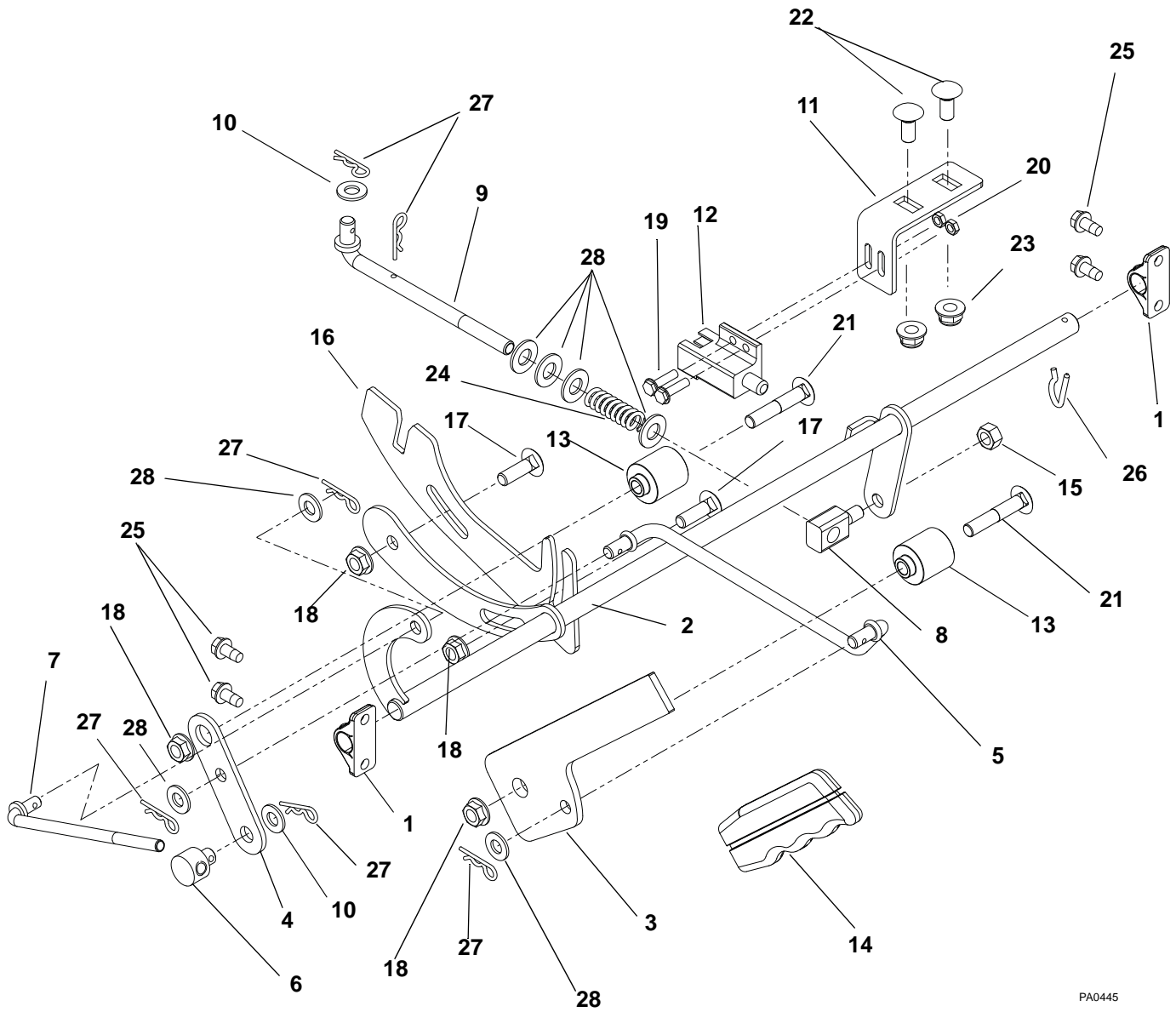

PA0445

# PARKING BRAKE

---

Model 916002

Item	Part No.	Qty.	Description
1	03757501	2	Bushing, .50 Clamp Block Molded
2	03824500	1	Weldment, Brake Cross Shaft
3	03824651	1	Handle, Parking Brake
4	03824751	1	Bracket, Middle Parking Brake
5	03824800	1	Rod, Parking Brake Handle
6	01596400	1	Trunnion, Brake .31-18
7	00349800	1	Link, Brake
8	09267300	1	Pin, Pivot/Trunnion
9	03879000	1	Rod, Brake Link
10	06436200	2	Washer, Flat Steel .406 x .812 x .065
11	03829951	1	Bracket, Parking Switch Mount
12	08828100	1	Switch, Interlock
13	00476300	2	Spacer, Neutral Latch
14	03826900	1	Grip, Parking Brake (Yellow)
15	06529800	1	Nut, Locking Center .31-18
16	03825000	1	Interlock Forward/Reverse
17	06200007	2	Bolt, Round Head Square Neck .31-18 x 1
18	06543100	4	Nut, Locking Top Flange .31-18
19	06116900	2	Screw, Machine 10-24 x .75 Hex Washer Head
20	06536000	2	Nut, Locking Nylon 10-24 With Insert
21	06213900	2	Bolt, Round Head Square Neck .31-18 x 1.75
22	06215700	2	Bolt, Round Head Square Neck .31-18 x .75
23	06545400	2	Nut, Nyloc Flange .31-18
24	08312500	1	Spring, Compression .093 x .59 x 1.50
25	07400034	4	Screw, Tapping .25-20 x .50 Hex Washer Head Thread Rolling
26	06944800	1	Clip, Spring
27	06713500	6	Pin, Internal Hair .08 x .18 x 1.18
28	06437200	7	Washer, Flat Steel .344 x .688 x .065



# DIRECTIONAL CONTROL

## Model 916002

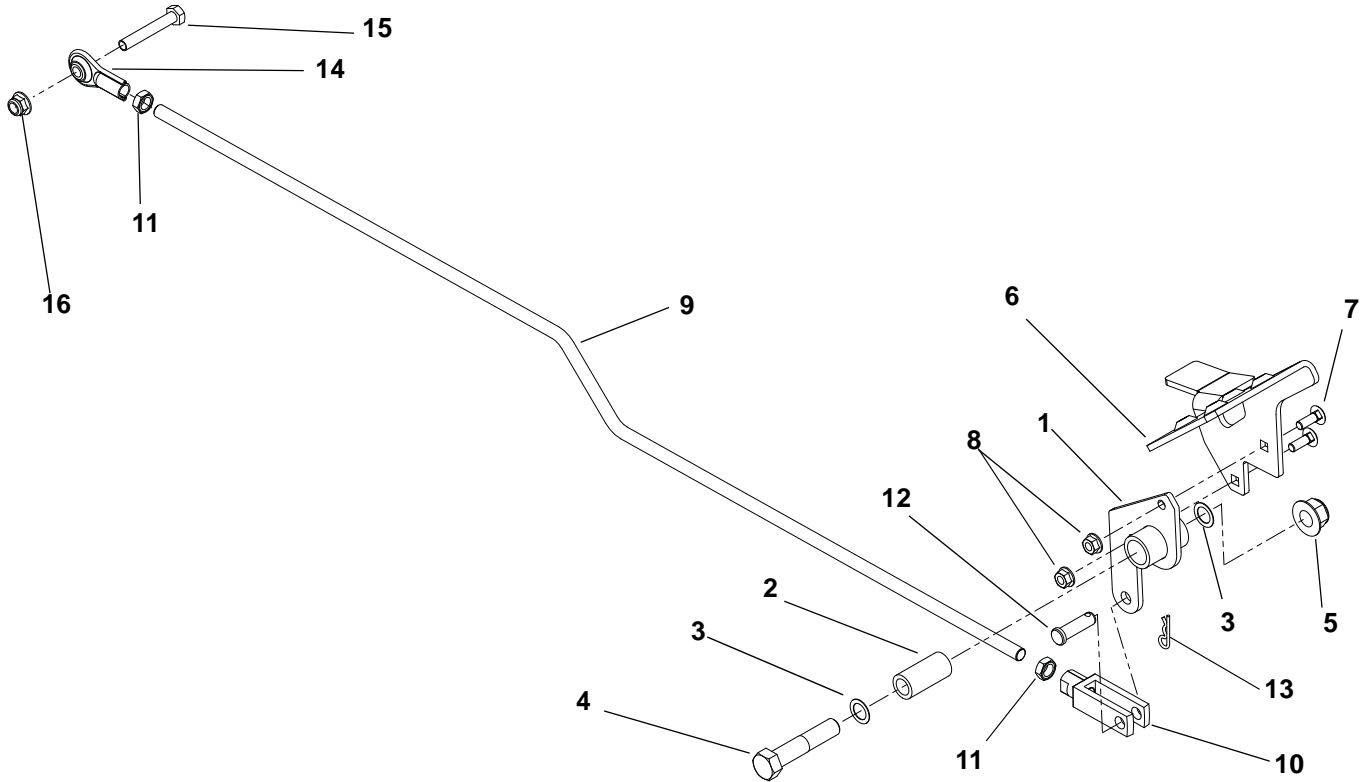

PA0440

Item	Part No.	Qty.	Description
1	03768351	1	Weldment, Foot Pedal
2	05516400	1	Bushing, Sleeve .500 x .750 x .560
3	06400015	2	Washer, Thrust .500 x .750 x .020
4	05966600	1	Bolt, Hex .50-13 x 2.50
5	06500010	1	Nut, Nyloc Flange .50-13
6	03782251	1	Foot Pedal, Top
7	06219900	2	Bolt, Round Head Square Neck .25-20 x .75
8	06543500	2	Nut, Locking Top Flange .25-20
9	03379400	1	Rod, Control
10	07000016	1	Clevis, Adjustable Swivel.38-24
11	06534700	2	Nut, Jam .375-24
12	06814900	1	Pin, Clevis .38 x 1.25
13	06713500	1	Pin, Internal Hair .08 x .18 x 1.18
14	03563100	1	Rod End, Right Hand .38
15	05980900	1	Bolt, Hex .31-18 x 2.00
16	06545400	1	Nut, Nyloc Flange .31-18

# NOTES

---

# STEERING CONTROLS

Model 916002

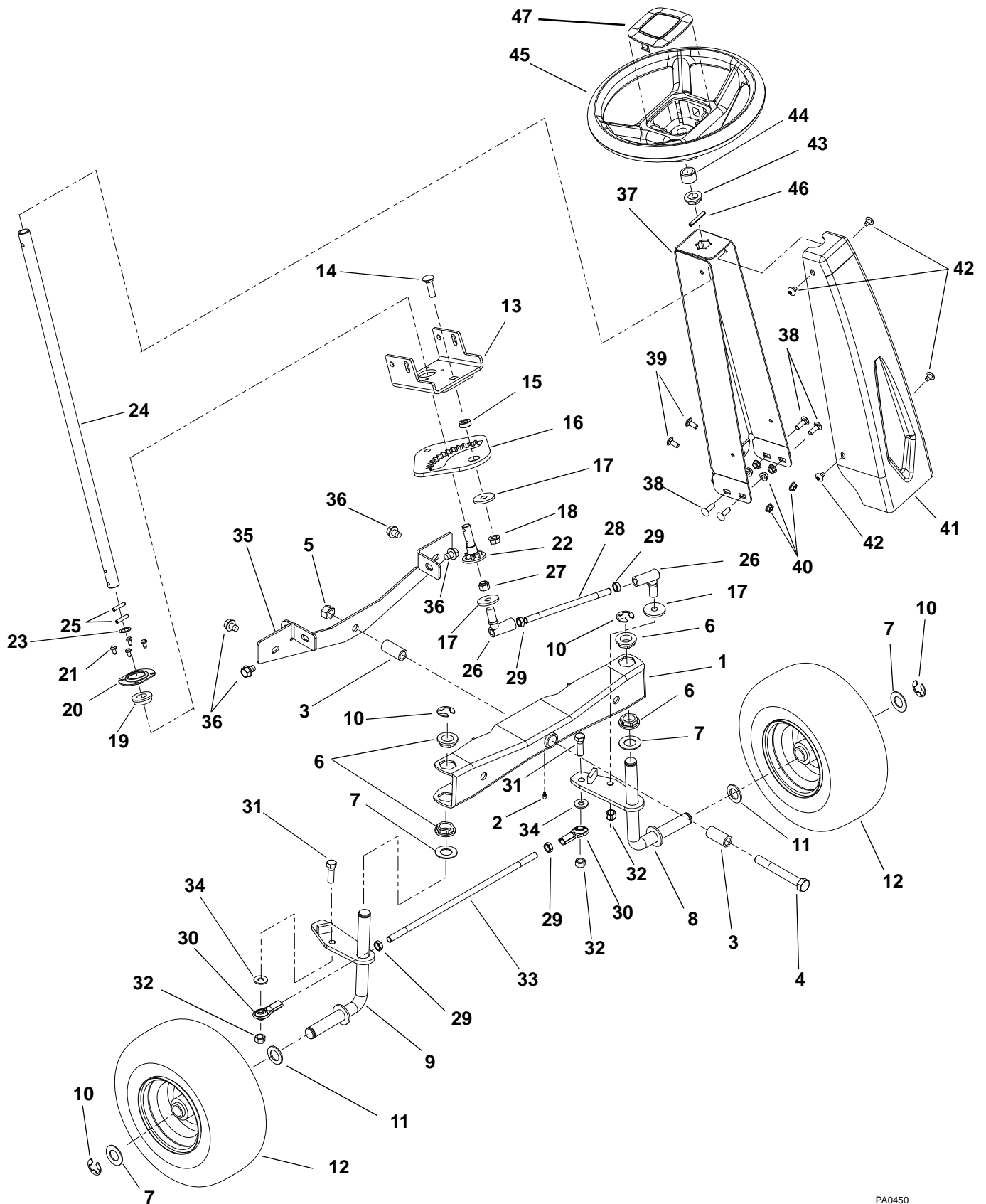

PA0450

# STEERING CONTROLS

Model 916002

Item	Part No.	Qty.	Description
1	03735951	1	Weldment, Pivoting Axle
2	07012600	1	Fitting, Lubrication .25-28 x .256
3	05516400	2	Bushing, Sleeve .500 x .750 x 1.560
4	05961900	1	Bolt, Hex .50-13 x 4.00
5	06536300	1	Nut, Locking Center .50-13
6	01212800	4	Bushing, Flange
7	06416100	4	Washer, Thrust
8	03368400	1	Weldment, Spindle Left Hand
9	03293500	1	Weldment, Spindle Right Hand
10	05707400	4	Ring, Retaining
11	06413300	2	Washer, Thrust .75
12	07100740	2	Tire/Wheel 11 x 4 4P K500
13	03751851	1	Support, Steering Gear
14	06224100	1	Bolt, Round Head Square Neck .38-16 x 1.25
15	02768400	1	Spacer, Steering Gear
16	03795000	1	Rack, Steering
17	06442400	3	Washer, Flat
18	06542000	1	Nut, Locking Top Flange .38-16
19	05505300	1	Bushing, Flange
20	01310000	1	Plate, Retaining
21	07414900	4	Screw, Tapping 10-24 x .375 Torx Pan Head
22	03841600	1	Pinion
23	06400015	1	Washer, Thrust .500 x .750 x .020
24	02749100	1	Shaft, Steering
25	05800138	2	Pin, Heavy Spiral .188 x 1.0
26	02917100	2	Joint, Ball
27	06538800	2	Nut, Nylon Lock .38-24
28	03368600	1	Rod, Steering
29	06534700	4	Nut, Jam .375-24
30	03563100	2	Rod End .38-16 Right Hand
31	05958000	2	Bolt, Hex .38-16 x 1.25
32	06529600	2	Nut, Locking Center .38-16
33	03368700	1	Tie Rod
34	06435700	2	Washer, Flat Steel .38 x .875 x .083
35	03829851	1	Support, Axle Mounting
36	07412900	4	Screw, Tapping .38-16 x .50 Hex Washer Head Thread Rolling
37	03376751	1	Back, Steering Column
38	06216100	4	Bolt, Round Head Square Neck .31-18 x 1
39	06215700	2	Bolt, Round Head Square Neck .31-18 x .75
40	06543100	6	Nut, Locking Top Flange .31-18
41	03376800	1	Cowl, Steering Column
42	07400009	4	Screw, Tapping Serrated Head Torx .31-18 x .50
43	01212800	1	Bushing, Flange
44	03781700	1	Sleeve, Steering
45	03781800	1	Wheel, Steering
46	05803700	1	Pin, Roll .250 x 1.75
47	03781801	1	Cover, Steering Wheel

# BATTERIES, CHARGER, GUARDS AND CLAMP

Model 916002

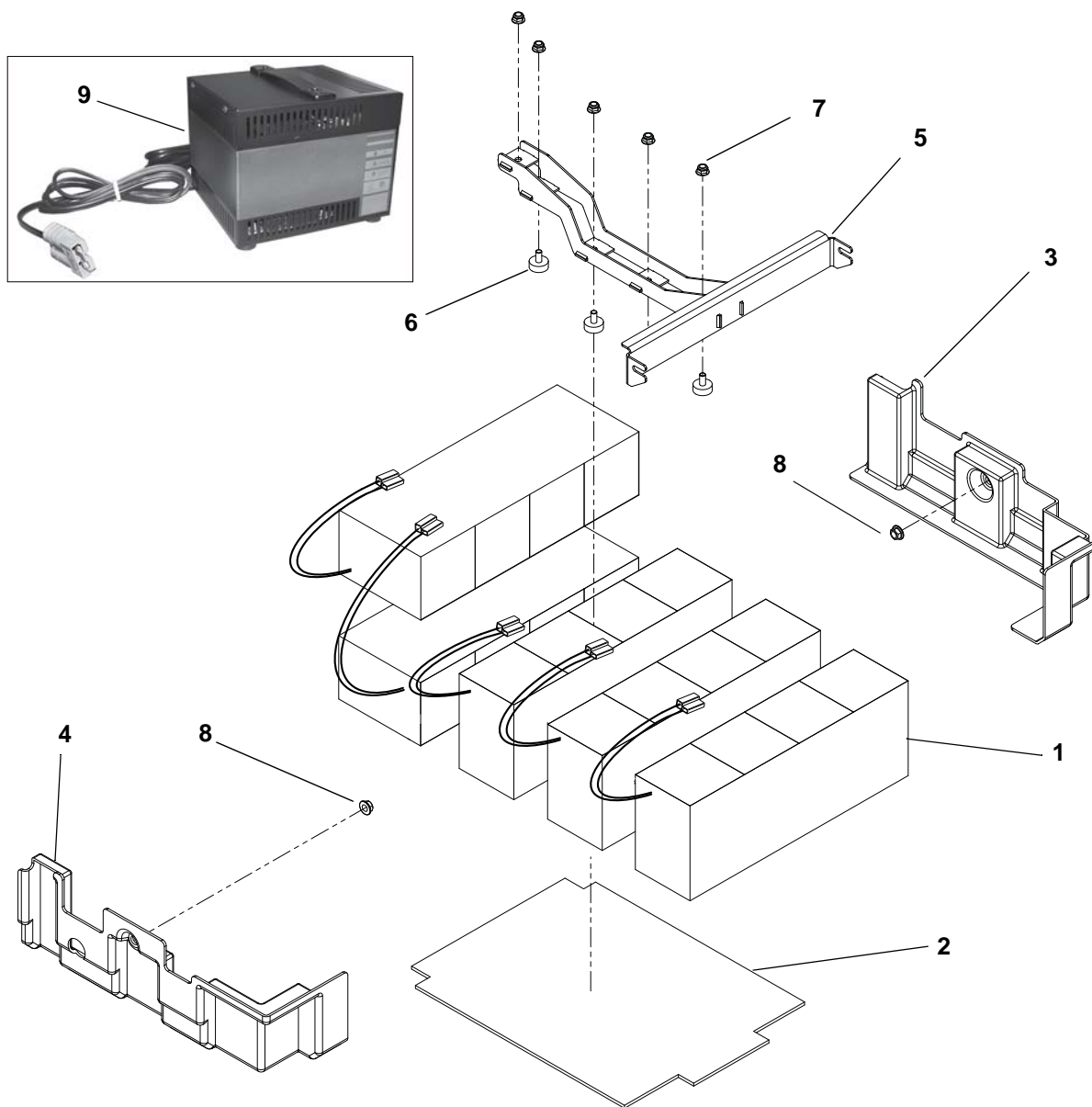

Item	Part No.	Qty.	Description
1	03793500	5	Battery, SBS Subpack – 48V 15AH
2	03787800	1	Mat, Rubber Battery
3	03830400	1	Guard, Plastic Battery Left Hand
4	03830500	1	Guard, Plastic Battery, Right Hand
5	03826851	1	Clamp, Battery
6	07533600	4	Bumper, Rubber
7	06545400	5	Nut, Nyloc Flange .31-18
8	06534800	2	Nut, Locking Flange .375-16
9	03793600	1	Charger, 48-Volt Battery

PA0455

# WIRING DIAGRAM AND HARNESS

Model 916002

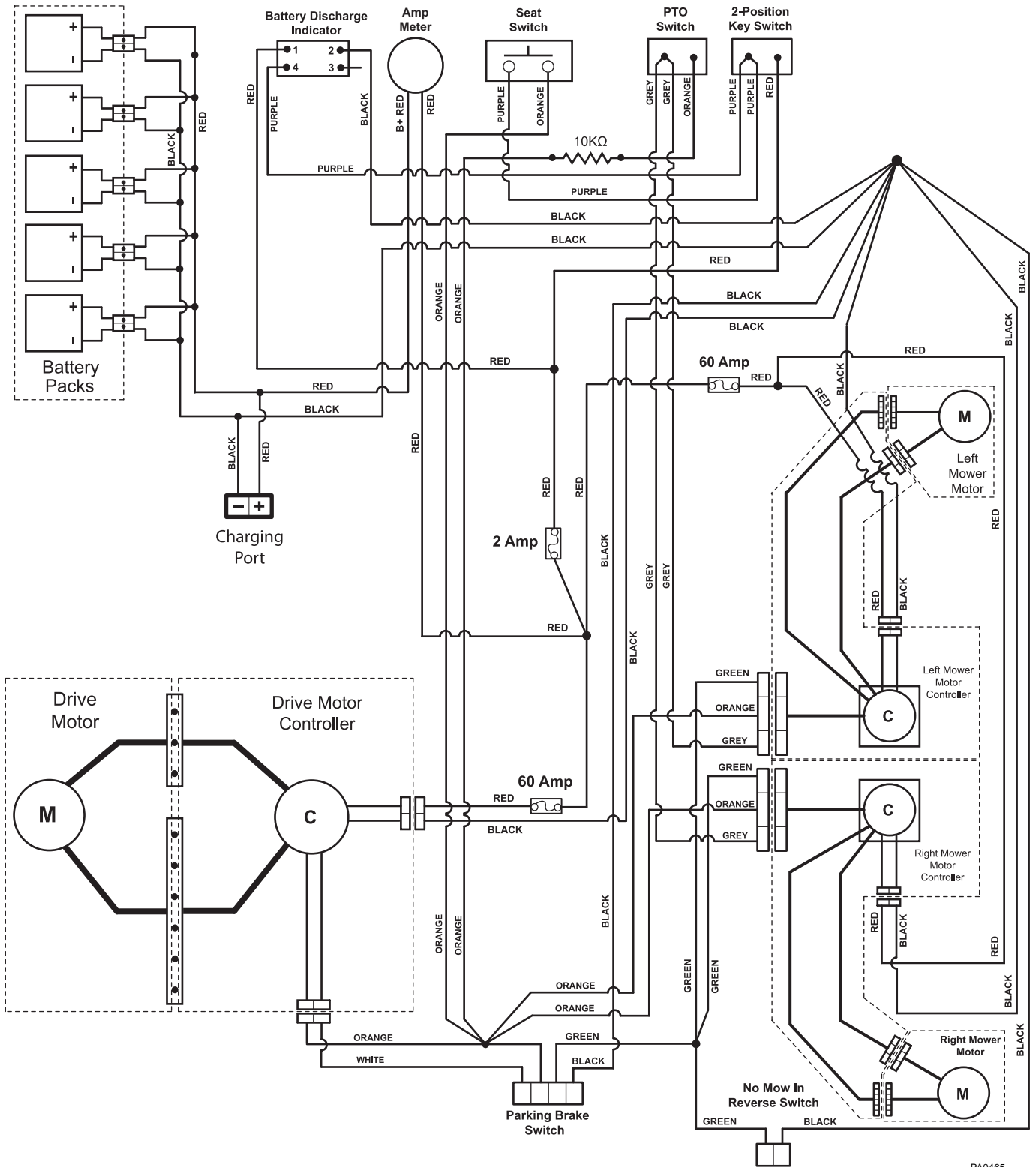

PA0465



Item	Part No.	Qty.	Description
N/A	03875900	1	Harness, Wiring, Single-Point Charge

# CONTINUITY DIAGRAM

## Model 916002

The diagrams below show the various states of connection for electrical components.  
The solid lines on switches show continuity.

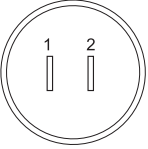
**NOTE:** All switches are viewed from the rear.

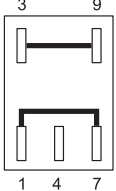
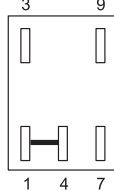
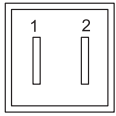
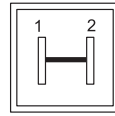
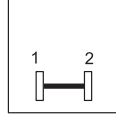
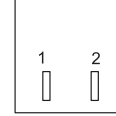
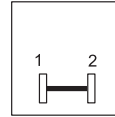
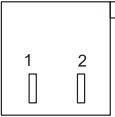
<p><b>Key Switch</b> (03796600)</p> <div style="display: flex; justify-content: space-around; align-items: center;"> <div style="text-align: center;">  <p>OFF</p> </div> <div style="text-align: center;">  <p>RUN</p> </div> </div>	<p><b>PTO Switch</b> (01545600)</p> <div style="display: flex; justify-content: space-around; align-items: center;"> <div style="text-align: center;">  <p>DISENGAGED (down position)</p> </div> <div style="text-align: center;">  <p>ENGAGED (up position)</p> </div> </div>
<p><b>Seat Switch</b> (03654200)</p> <div style="display: flex; justify-content: space-around; align-items: center;"> <div style="text-align: center;">  <p>OPERATOR OFF SEAT</p> </div> <div style="text-align: center;">  <p>OPERATOR ON SEAT</p> </div> </div>	<p><b>No Mow In Reverse Switch</b> (03657100)</p> <div style="display: flex; justify-content: space-around; align-items: center;"> <div style="text-align: center;">  <p>BUTTON IN</p> </div> <div style="text-align: center;">  <p>BUTTON OUT</p> </div> </div>
<p><b>Parking Brake Switch</b> (08828100)</p> <div style="display: flex; justify-content: space-around; align-items: center;"> <div style="text-align: center;">  <p>BUTTON IN</p> </div> <div style="text-align: center;">  <p>BUTTON OUT</p> </div> </div>	

# MOWER DECK LIFT

Model 916002

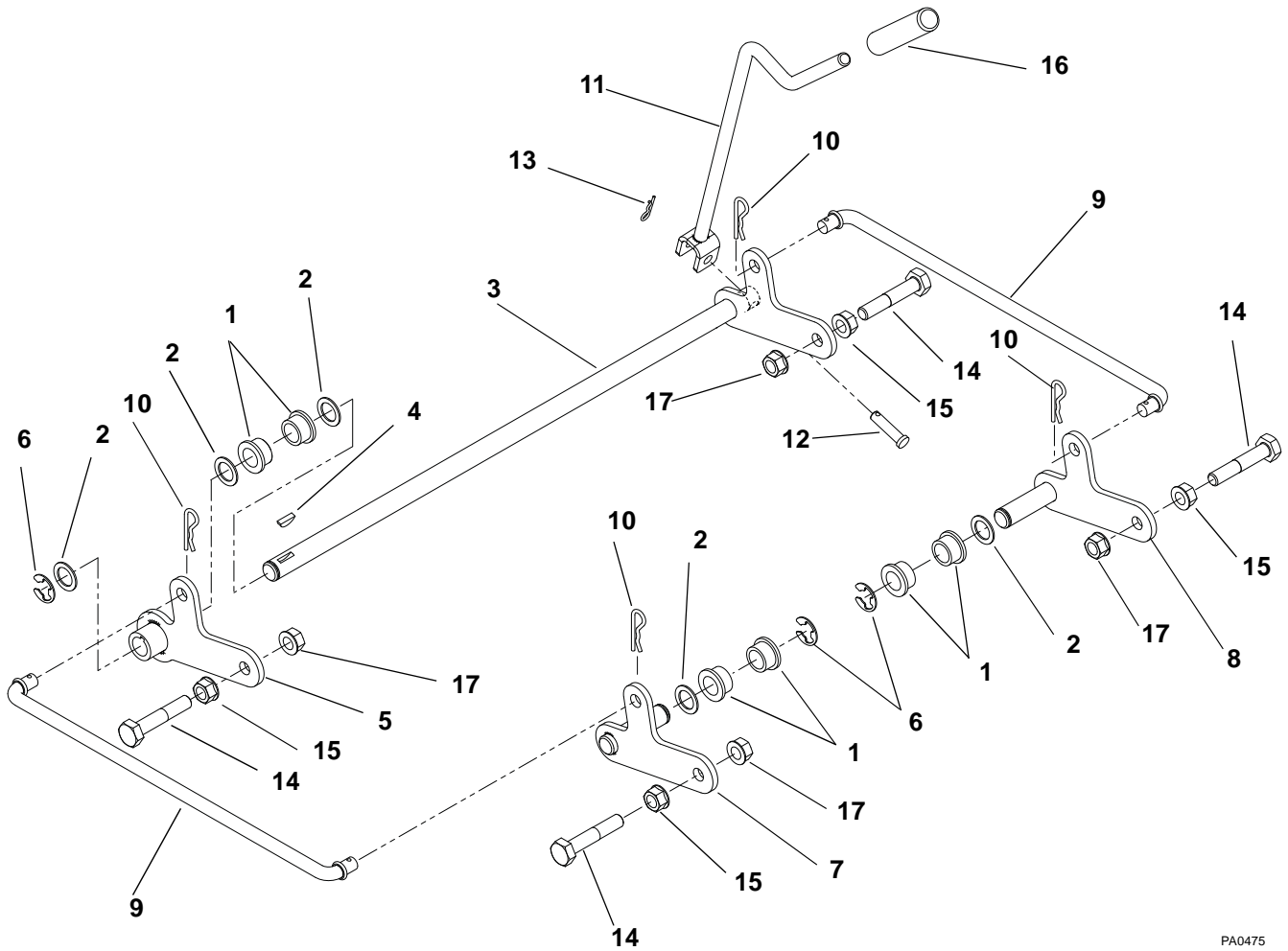

PA0475

Item	Part No.	Qty.	Description
1	05503900	6	Bushing, Flange .75 ID
2	06441400	5	Washer, Flat Steel .754 x 1.12 x .062
3	03385500	1	Weldment, Deck Lift
4	06600300	1	Key, Woodruff .188 x .75 x .313 SAE 9
5	03386900	1	Weldment, Keyed Deck Lift Arm
6	05707400	3	Ring, External Retaining .750 x .050
7	03385400	1	Weldment, Deck Lift Arm Right Hand
8	03399100	1	Weldment, Deck Lift Arm Left Hand
9	00279900	2	Rod, Lift
10	06714900	4	Pin, External Hair #16
11	03389951	1	Weldment, Deck Lift Handle
12	06810200	1	Pin, Clevis .370 x 1.50
13	06713500	1	Pin, Internal Hair .08 x .18 x 1.18
14	05953500	4	Bolt, Hex .50-13 x 2.75
15	06543300	4	Nut, Spin Lock Flange .50-13
16	07500107	1	Grip .475 I.D. x 4.25
17	06500010	4	Nut .50-13 Nyloc Flange



# MOWER DECK, MOTORS AND BLADES

Model 916002

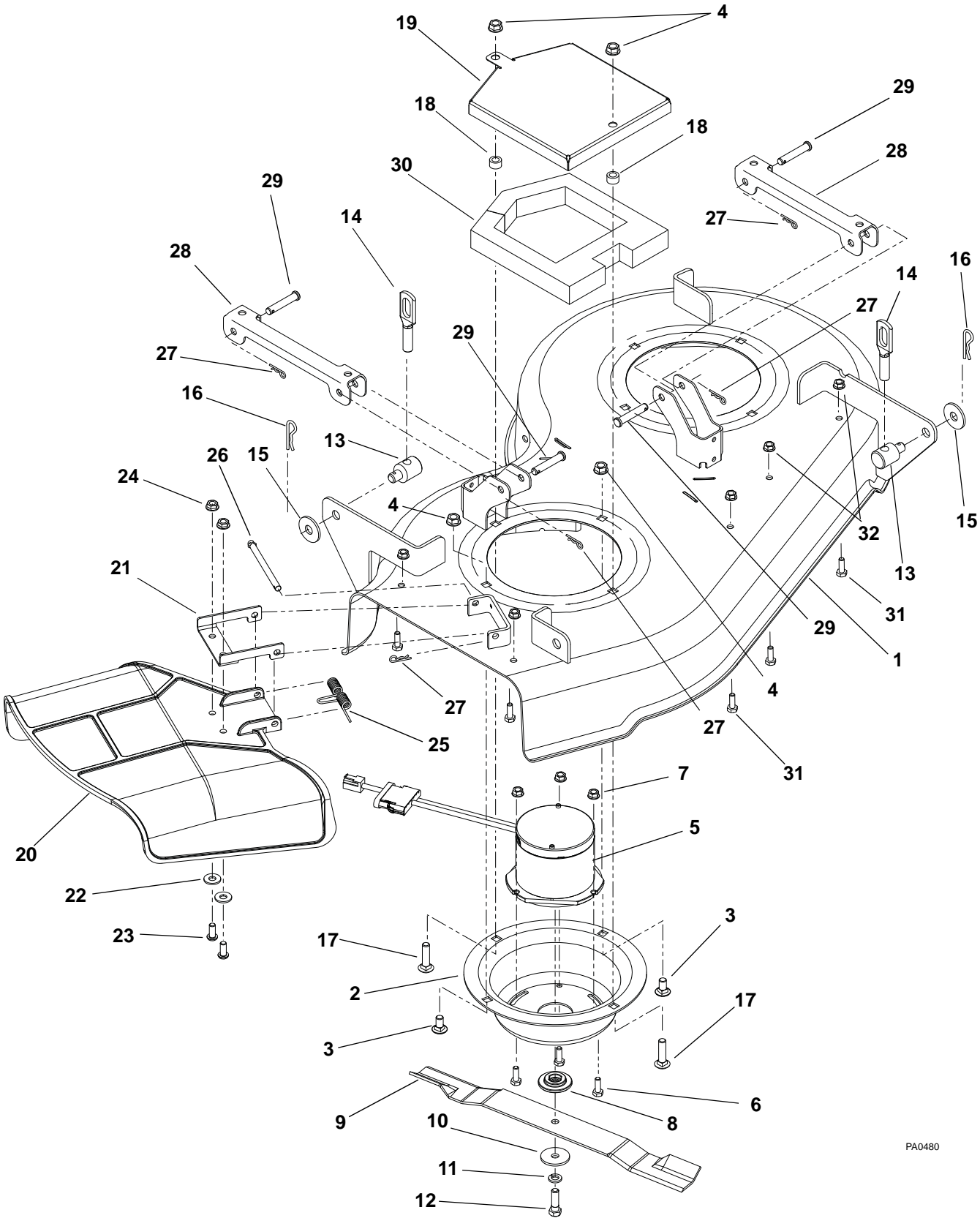

PA0480

# MOWER DECK, MOTORS AND BLADES

---

Model 916002

Item	Part No.	Qty.	Description
1	03299459	1	Deck, 34" Stamped Electric
2	03372359	2	Sump, Deck
3	06223900	4	Bolt, Round Head Square Neck .38-16 x .75
4	06542000	12	Nut, Locking Top Flange .38-16
5	03729200	2	Motor, 1.7 HP Electric Brushless
6	05946800	6	Bolt, Hex .25-20 x .75
7	06500012	6	Nut, Nyloc Flange .25-20
8	03722300	2	Adapter, Mower Blade
9	01968000	2	Mower Blade 12 x 1.125
10	06441700	2	Washer, Flat Steel .39 x 1.5 x .125
11	06308800	2	Washer, Locking .38 x .094 Regular
12	05930900	2	Bolt, Hex .38-24 x 1.25 Grade 8
13	01590400	4	Trunnion .50
14	00160000	4	Link, Deck
15	06436400	4	Washer, Flat Steel .511 x 1.44 x .125
16	06714900	4	Pin, External Hair #16
17	06223800	4	Bolt, Round Head Square Neck .38-16 x 1.75
18	05500916	4	Bushing, Spacer .380 x .625 x .625
19	03768059	2	Cover, Motor
20	00499900	1	Chute, Molded
21	00662651	1	Reinforcement, Chute
22	06435700	2	Washer, Flat Steel .38 x .875 x .083
23	05920900	2	Screw, Socket Head .31-18 x .75 Button Head
24	06543100	2	Nut, Locking Top Flange .31-18
25	01258100	1	Spring, Torsion
26	06800002	1	Pin .312 x 3.88
27	06713500	5	Pin, Internal Hair .08 x .18 x 1.18
28	03764059	2	Bracket, Stabilizer Link
29	06800102	4	Pin, Clevis .375 x 2.00
30	03830000	2	Foam, Deck Motor Cover
31	05947000	5	Bolt, Hex .31-18 x .75
32	06530400	5	Nut, Spin Lock Flange .312-18



Ariens Company  
655 West Ryan Street  
Brillion, WI 54110-1072  
920-756-2141  
Fax 920-756-2407  
[www.ariens.com](http://www.ariens.com)  
[www.ampbyariens.com](http://www.ampbyariens.com)